

Technical training.
Product information.

G12 General Vehicle Electronics



BMW Service

Edited for the U.S. market by:
BMW Group University
Technical Training

ST1501

8/1/2015

General information

Symbols used

The following symbol is used in this document to facilitate better comprehension or to draw attention to very important information:



Contains important safety information and information that needs to be observed strictly in order to guarantee the smooth operation of the system.

Information status and national-market versions

BMW Group vehicles meet the requirements of the highest safety and quality standards. Changes in requirements for environmental protection, customer benefits and design render necessary continuous development of systems and components. Consequently, there may be discrepancies between the contents of this document and the vehicles available in the training course.

This document basically relates to the European version of left hand drive vehicles. Some operating elements or components are arranged differently in right-hand drive vehicles than shown in the graphics in this document. Further differences may arise as the result of the equipment specification in specific markets or countries.

Additional sources of information

Further information on the individual topics can be found in the following:

- Owner's Handbook
- Integrated Service Technical Application.

Contact: conceptinfo@bmw.de

©2015 BMW AG, Munich

Reprints of this publication or its parts require the written approval of BMW AG, Munich

The information contained in this document forms an integral part of the technical training of the BMW Group and is intended for the trainer and participants in the seminar. Refer to the latest relevant information systems of the BMW Group for any changes/additions to the technical data.

Information status: **June 2015**
BV-72/Technical Training

G12 General Vehicle Electronics

Contents

1. Exterior Lights	1
1.1. System wiring diagram	2
1.2. Lighting, front	5
1.2.1. Adaptive LED Headlight	6
1.2.2. Icon Adaptive LED Headlight	7
1.3. Lighting, rear	8
1.4. High-beam assistant	9
1.4.1. System wiring diagram	10
1.5. Exterior light staging	10
1.5.1. System wiring diagram	11
1.5.2. Ground lights	12
1.5.3. Light carpet	13
2. Interior Lights	14
2.1. Basic	14
2.1.1. System wiring diagram	14
2.2. Ambient lighting	16
2.2.1. System wiring diagram	17
2.3. Light Effect Manager	19
2.3.1. System wiring diagram	20
2.3.2. System components	22
3. Washer/wiper System	25
3.1. System wiring diagram	25
4. Locking and Security Functions	27
4.1. Comfort Access	27
4.1.1. System wiring diagram	27
4.2. Central locking system	29
4.2.1. System wiring diagram	29
4.2.2. Function	30
4.3. Automatic operation of tailgate	31
4.3.1. System wiring diagram	31
4.4. Automatic Soft Close system	33
4.4.1. System wiring diagram	33
5. Alarm System	35
5.1. System wiring diagram	35
6. Power Window Regulator	37
6.1. System wiring diagram	37

G12 General Vehicle Electronics

Contents

7. Slide/Tilt Sunroof	39
7.1. System wiring diagram.....	39
8. Roller Sunblind	41
8.1. System wiring diagram.....	41
9. Steering Column Switch Cluster	43
9.1. System wiring diagram.....	43
10. Steering Column Adjustment	45
10.1. System wiring diagram.....	45
11. Exterior Mirrors	47
11.1. Exterior mirror, basic version.....	47
11.1.1. System wiring diagram.....	47
11.2. Exterior mirror High.....	49
11.2.1. System wiring diagram.....	49
12. Inside Mirror	51
12.1. System wiring diagram.....	51
13. Seats	52
13.1. Front seats.....	52
13.1.1. Memory seat, front, driver's side.....	52
13.1.2. Memory seat, front, passenger's side.....	54
13.1.3. Multifunction seat, front, driver's side.....	56
13.1.4. Multifunction seat, front, passenger's side.....	58
13.2. Rear seats.....	60
13.2.1. Seat heating, basic seat, rear passenger compartment.....	60
13.2.2. Comfort seat, rear passenger compartment, driver's side.....	62
13.2.3. Comfort seat, rear passenger compartment, passenger's side.....	64
13.3. Captain's Chair.....	65
13.4. Massage.....	68
13.4.1. Seat massage, both front seats.....	69
13.4.2. Seat massage, rear passenger compartment, and massage, front.....	71
13.5. Heated armrests.....	72
13.5.1. System wiring diagram.....	73
13.6. BMW Vitality Program.....	74
14. Horn	75
14.1. System wiring diagram.....	75

G12 General Vehicle Electronics

1. Exterior Lights

The following exterior light versions are offered in the G12:

- Adaptive LED Headlights (SA ZAL)
- Icon Adaptive LED headlights (SA 552)

G12 General Vehicle Electronics

1. Exterior Lights

1.1. System wiring diagram

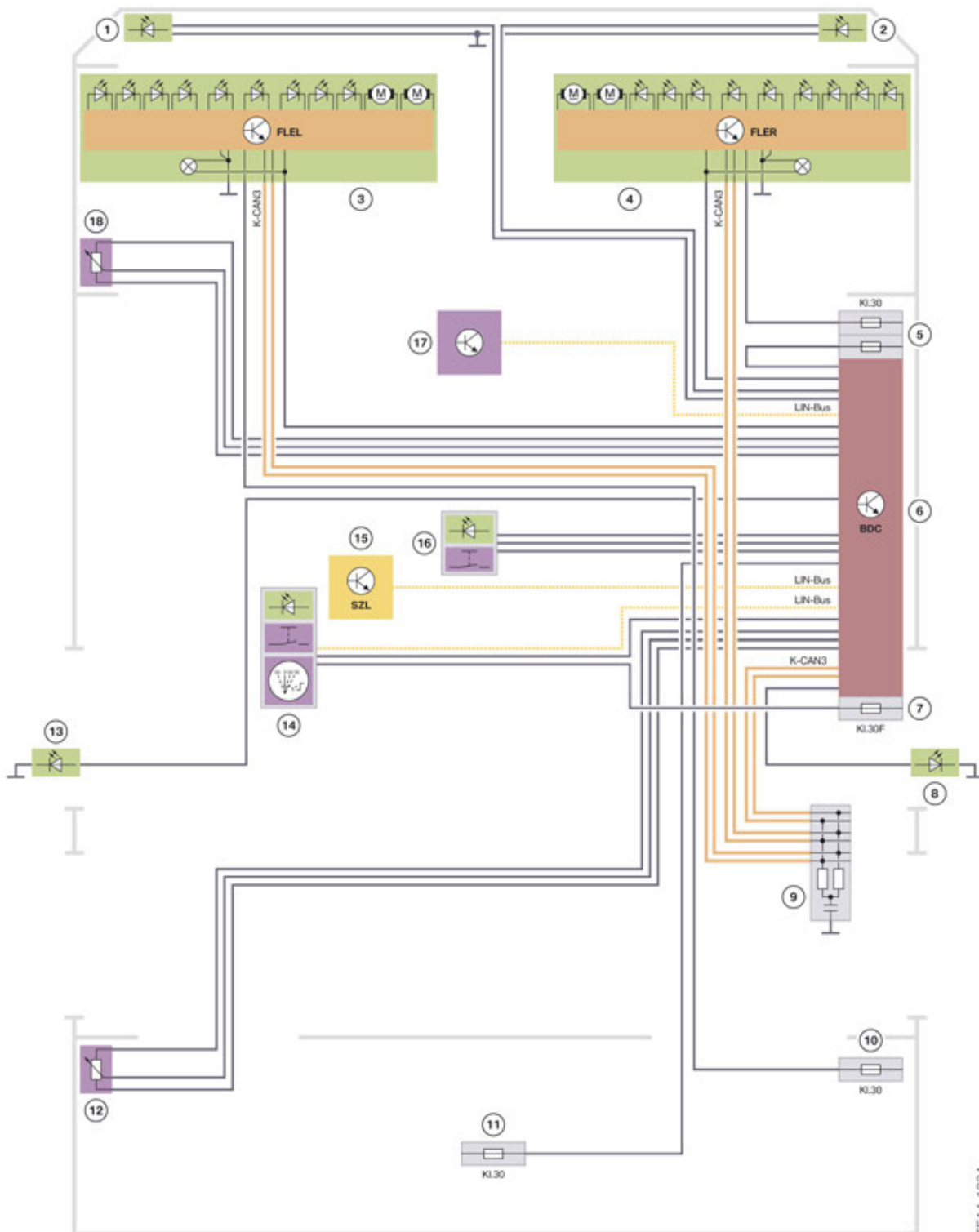

TE14-1234

Front exterior lights

G12 General Vehicle Electronics

1. Exterior Lights

Index	Explanation
1	Left fog light
2	Right fog light
3	Left headlight with Front Light Electronics Left (FLEL)
4	Right headlight with Front Light Electronics Right (FLER)
5	Fuses in the power distribution box, front right
6	Body Domain Controller (BDC)
7	Fuse in the Body Domain Controller
8	Turn indicator in exterior mirror, right
9	CAN terminator
10	Fuse in the power distribution box, rear right
11	Fuse in the power distribution box, battery
12	Ride-height sensor, rear left
13	Turn indicator in exterior mirror, left
14	Light switch
15	Steering column switch cluster (SZL)
16	Hazard warning switch/Intelligent Safety button
17	Rain-light-solar-condensation sensor (RLSBS)
18	Ride height sensor, front left

G12 General Vehicle Electronics

1. Exterior Lights

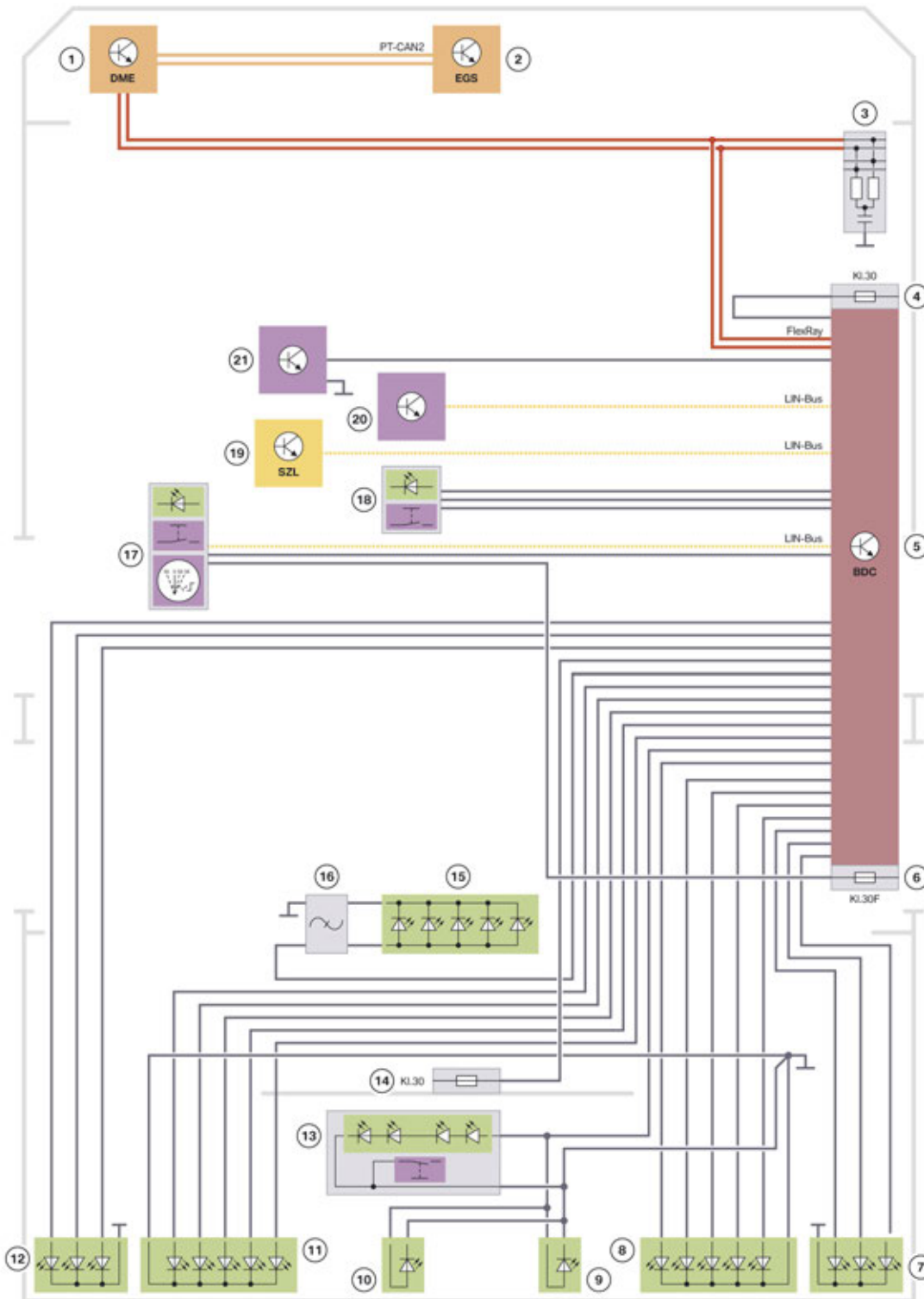

Rear exterior lights

TE14-1235

G12 General Vehicle Electronics

1. Exterior Lights

Index	Explanation
1	Digital Motor Electronics (DME)
2	Electronic transmission control (EGS)
3	CAN terminator
4	Fuses in the power distribution box, front right
5	Body Domain Controller (BDC)
6	Fuse in the Body Domain Controller
7	Rear light cluster, right outer
8	Rear light cluster, right inner
9	License plate light, right
10	License plate light, left
11	Rear light cluster, left inner
12	Rear light cluster, left outer
13	License plate light strip with button for tailgate
14	Fuse in the power distribution box, battery
15	Additional brake light
16	Interference suppression filter
17	Light switch
18	Hazard warning switch/Intelligent Safety button
19	Steering column switch cluster (SZL)
20	Rain-light-solar-condensation sensor (RLSBS)
21	Brake light switch

1.2. Lighting, front

Headlight versions for G12:



Headlight versions

Index	Explanation
1	Adaptive LED Headlight
2	Icon Adaptive LED Headlight

G12 General Vehicle Electronics

1. Exterior Lights

1.2.1. Adaptive LED Headlight

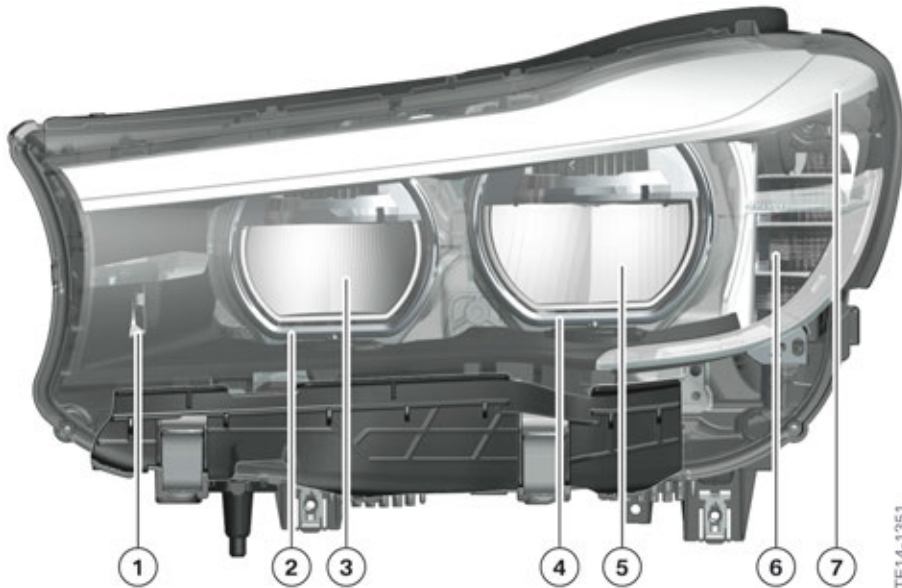

Basic LED headlights

Index	Explanation
1	Cornering light
2	Side lights and daytime running lights
3	Low-beam headlight/High-beam headlight
4	Side lights and daytime running lights
5	Low-beam headlight/High-beam headlight
6	Turn indicator
7	Side marker light

On the Adaptive LED headlight, the low-beam headlight and high beam are located in the same reflector.

G12 General Vehicle Electronics

1. Exterior Lights

1.2.2. Icon Adaptive LED Headlight

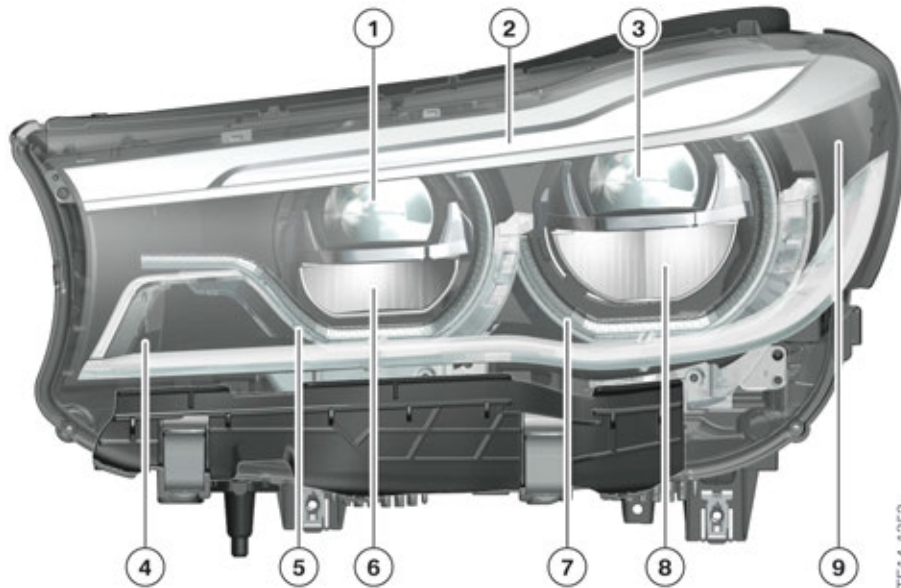

Adaptive Full LED Headlight

Index	Explanation
1	Low-beam headlight
2	Turn indicator
3	Low-beam headlight
4	Cornering lights
5	Side light, daytime running lights
6	High-beam headlight
7	Side light, daytime running lights
8	High-beam headlight
9	Side marker light

On the Icon Adaptive LED Headlight, the low beams have their own projector lenses and are separate from the high beam.

G12 General Vehicle Electronics

1. Exterior Lights

1.3. Lighting, rear

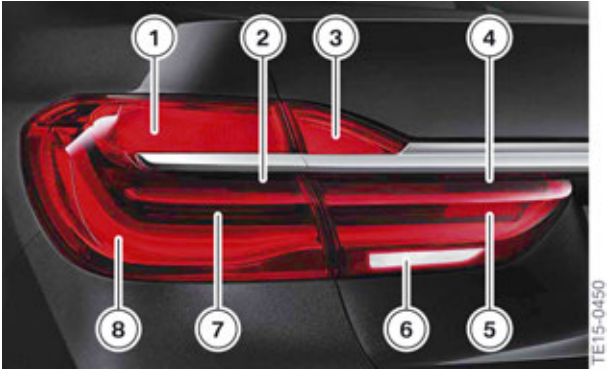

Taillight

Index	Explanation
1	Turn indicator
2	Taillight
3	Turn indicator
4	Rear fog light (Not for US)
5	Rear fog light (Not for US)
6	Reversing light
7	Brake light
8	Taillight

G12 General Vehicle Electronics

1. Exterior Lights

1.4. High-beam assistant

On vehicles with camera-based driver assistance systems (KAFAS), the function of the high-beam assistant is performed by KAFAS.

On vehicles without camera-based driver assistance systems (KAFAS), the high-beam assistant is integrated in the interior mirror.



High-beam assistant (FLA)

G12 General Vehicle Electronics

1. Exterior Lights

1.4.1. System wiring diagram

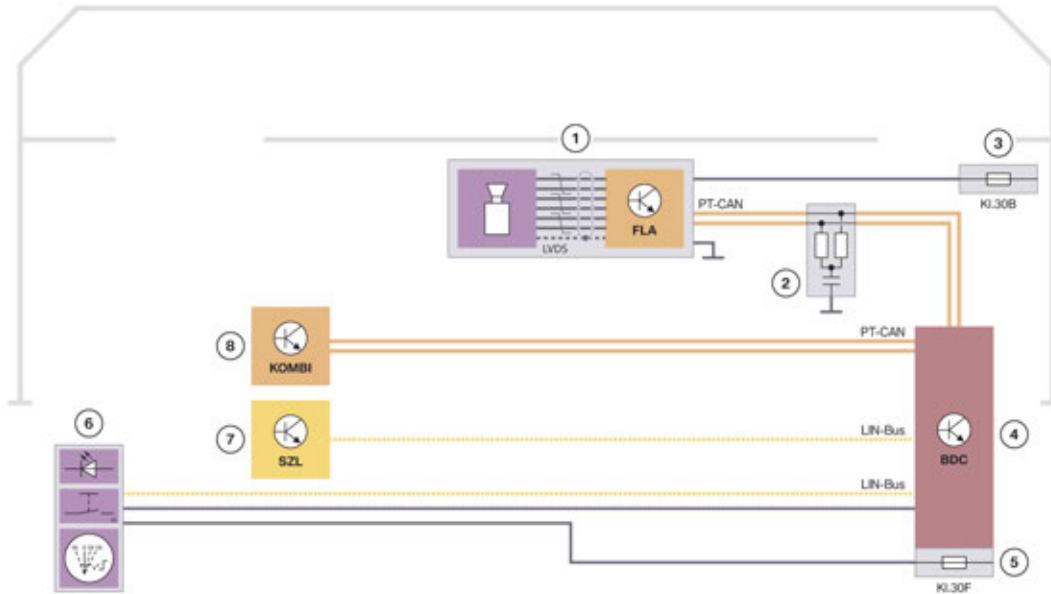

TE15-0039

High-beam assistant

Index	Explanation
1	High-beam assistant (FLA)
2	CAN terminator
3	Fuse in the power distribution box, front right
4	Body Domain Controller (BDC)
5	Fuse in the Body Domain Controller
6	Light switch
7	Steering column switch cluster (SZL)
8	Instrument cluster (KOMBI)

1.5. Exterior light staging

The exterior light staging for the G12 may include the following items, depending on the optional equipment:

- Ground lights
- Light carpet

G12 General Vehicle Electronics

1. Exterior Lights

1.5.1. System wiring diagram

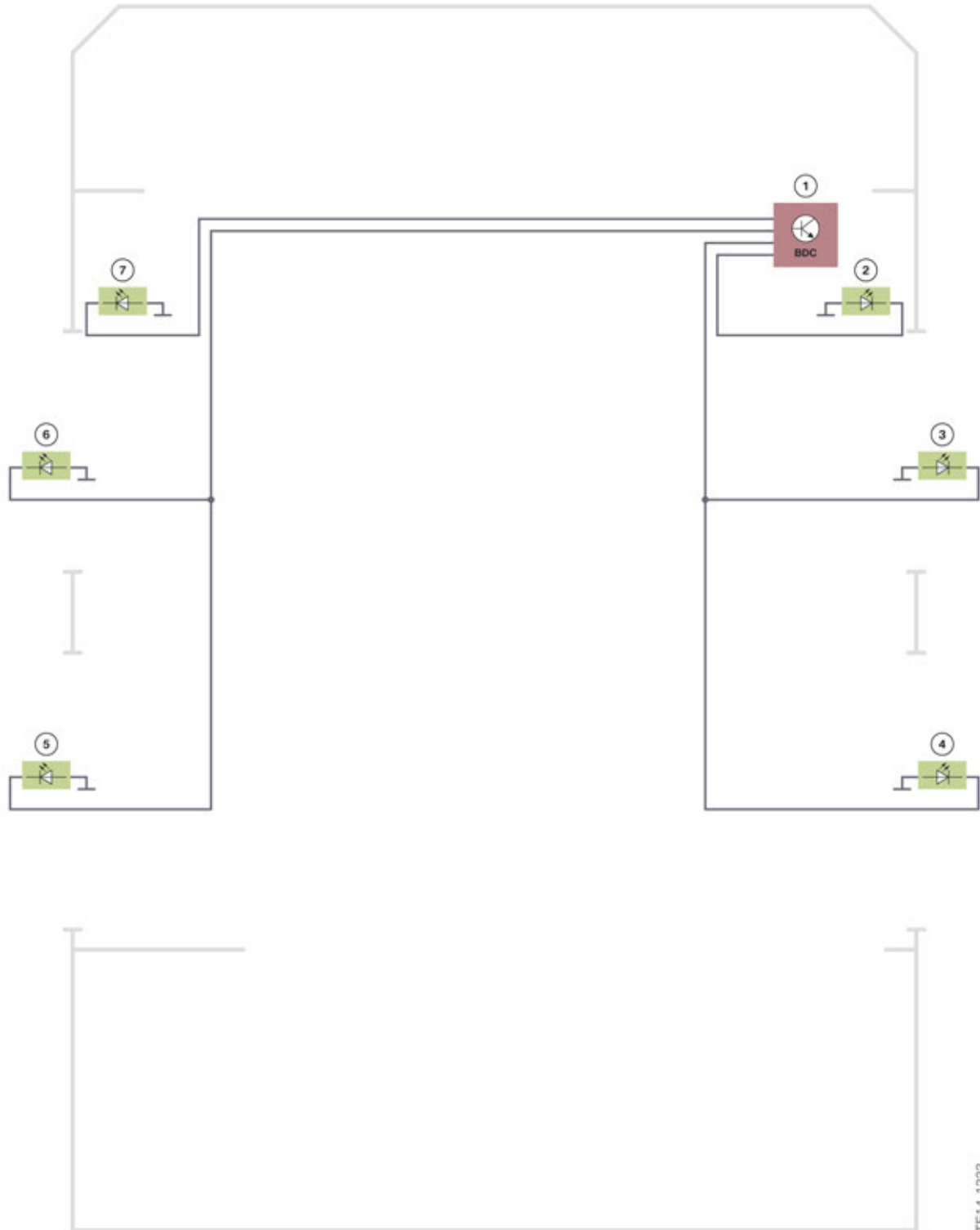

Exterior light staging

TE14-1223

G12 General Vehicle Electronics

1. Exterior Lights

Index	Explanation
1	Light carpet, left
2	Light carpet, right
3	Body Domain Controller (BDC)
4	Door entry light in front passenger door
5	Door entry light in the rear passenger's side door
6	Door entry light in the rear driver's side door
7	Door entry light in the driver's door

1.5.2. Ground lights

The ground lighting is integrated in the corresponding door modules. The LEDs of the ground lighting are activated by the Body Domain Controller (BDC).

G12 General Vehicle Electronics

1. Exterior Lights

1.5.3. Light carpet

The light source is integrated into the side sill, where it is invisible to the customer. This feature can be in a very small installation space through the use of a multi-lens design system. A very flat angle of radiation is also possible. The graphic is superimposed several times by the multi-lens design system and is therefore insensitive to dirt contamination. The light carpet is activated by the Body Domain Controller (BDC).

LEDs in the side sill



LEDs in the side sill

Light carpet



Light carpet

G12 General Vehicle Electronics

2. Interior Lights

2.1. Basic

2.1.1. System wiring diagram

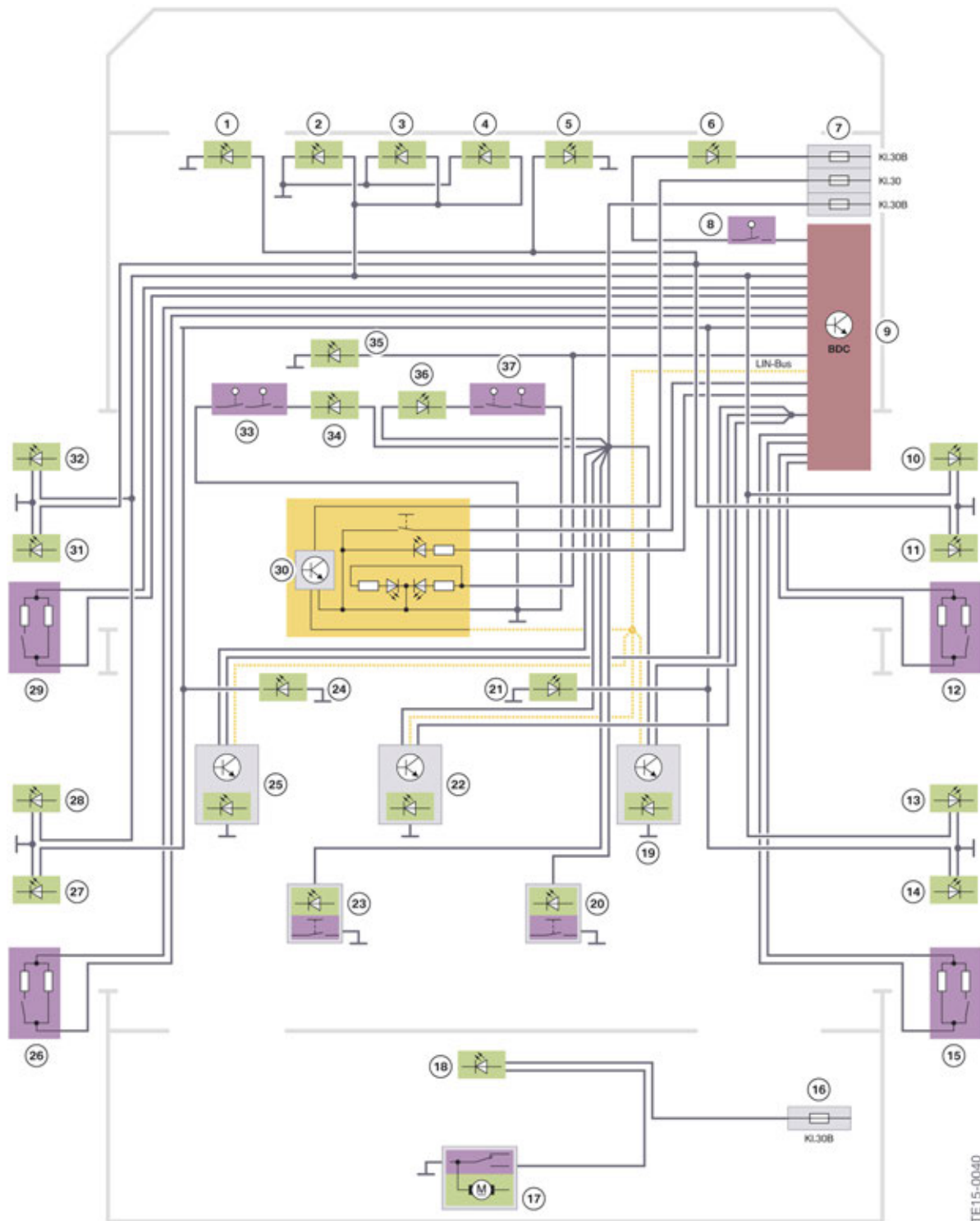

Basic interior light

G12 General Vehicle Electronics

2. Interior Lights

Index	Explanation
1	Footwell light, front left
2	Ambient lighting, dashboard
3	Ambient lighting, dashboard
4	Ambient lighting, dashboard
5	Footwell light, front right
6	Glove box light
7	Fuses in the power distribution box, front right
8	Glove box switch
9	Body Domain Controller (BDC)
10	Door trim panel lighting, passenger's side
11	Door entry light, front passenger side
12	Door contact, front passenger side, front
13	Door trim panel lighting, passenger's side rear
14	Door entry light, passenger's side rear
15	Door contact on front passenger side, rear
16	Fuse in the power distribution box, rear right
17	Tailgate contact switch in the tailgate lock
18	Luggage compartment light
19	Interior light, rear right (on vehicles with panorama glass roof)
20	Make-up mirror light, rear right
21	Footwell light, rear right
22	Interior light, rear center (on vehicles without panorama glass roof)
23	Make-up mirror light, rear left
24	Footwell light, rear left
25	Interior light, rear left (on vehicles with panorama glass roof)
26	Door contact on driver's side, rear
27	Door entry light, driver's side rear
28	Door trim panel lighting, driver's side rear
29	Door contact, driver's side, front
30	Front interior light
31	Door entry light, driver's side
32	Door trim panel lighting, driver's side
33	Switch for make-up mirror, left

G12 General Vehicle Electronics

2. Interior Lights

Index	Explanation
34	Make-up mirror light, left
35	Center console storage compartment lighting
36	Make-up mirror light, right
37	Switch for make-up mirror, right

In the basic interior lighting configuration, the following interior lights are connected with the Body Domain Controller via LIN-bus:

- Interior light in the roof function center (FZD)
- Interior light in the center of the rear passenger compartment on vehicles without panorama glass roof
- Interior lights on the left and right of the rear passenger compartment on vehicles with panorama glass roof

The glove box light is switched by the glove box switch.

The luggage compartment light is switched by the tailgate contact switch in the tailgate lock.

All other interior lights are activated directly by the Body Domain Controller.

Depending on the optional equipment, the G12 has different light elements for the interior lighting.

2.2. Ambient lighting

The ambient lighting includes 6 predefined, selectable light designs/colors.

The light design/color and brightness can be selected by means of the controller. The selected design is displayed on the CID.

G12 General Vehicle Electronics

2. Interior Lights

2.2.1. System wiring diagram

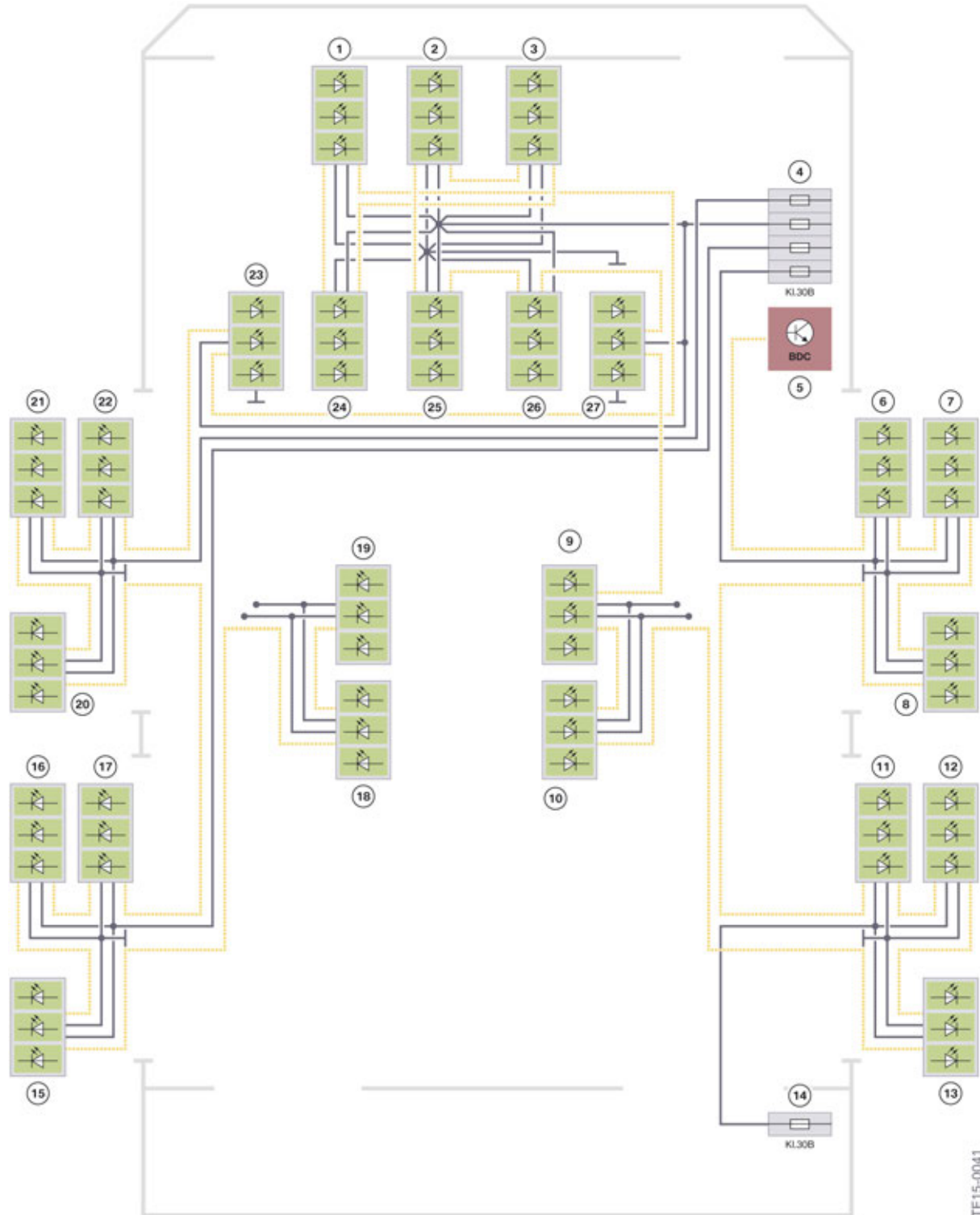

Interior lighting, ambient lighting

TE15-0041

G12 General Vehicle Electronics

2. Interior Lights

Index	Explanation
1	Ambient lighting, instrument panel, driver's side
2	Ambient lighting, instrument panel, passenger's side
3	Ambient lighting, instrument panel, passenger's side
4	Fuses in the power distribution box, front right
5	Body Domain Controller (BDC)
6	Lighting for door storage compartment, passenger's side
7	Door trim panel lighting, passenger's side
8	Door contour lighting, passenger's side
9	Backrest lighting, front passenger seat
10	Footwell lighting, passenger's side rear
11	Lighting for door storage compartment, passenger's side rear
12	Door trim panel lighting, passenger's side rear
13	Door contour lighting, passenger's side rear
14	Fuse in the power distribution box, rear right
15	Door contour lighting, driver's side rear
16	Door trim panel lighting, driver's side rear
17	Door storage compartment lighting, driver's side rear
18	Footwell lighting, driver's side rear
19	Backrest lighting, driver's seat
20	Door contour lighting, driver's side
21	Door trim panel lighting, driver's side
22	Door storage compartment lighting, driver's side
23	Footwell light, front left
24	Contour lighting, instrument panel, driver's side
25	Contour lighting, instrument panel, passenger's side
26	Contour lighting, instrument panel, passenger's side
27	Footwell light, front right

RGB (red, yellow, blue) LED modules are used for ambient lighting in the G12.

The ambient interior lighting is controlled via a separate local interconnect network bus. All the individual LED modules are connected in series via LIN-bus.

If the local interconnect network bus is interrupted at one location or the microcontroller at the LED is defective, the other light source is interrupted at this location. A search for the fault must be carried out at the location where the last LED illuminates.

G12 General Vehicle Electronics

2. Interior Lights

2.3. Light Effect Manager

The following lights are controlled via the Light Effect Manager (LEM):

- Lighting of the panorama glass roof
- Lighting of the light sabers at the B-pillars of the G12
- Lighting of the speaker covers in the High End audio system

G12 General Vehicle Electronics

2. Interior Lights

2.3.1. System wiring diagram

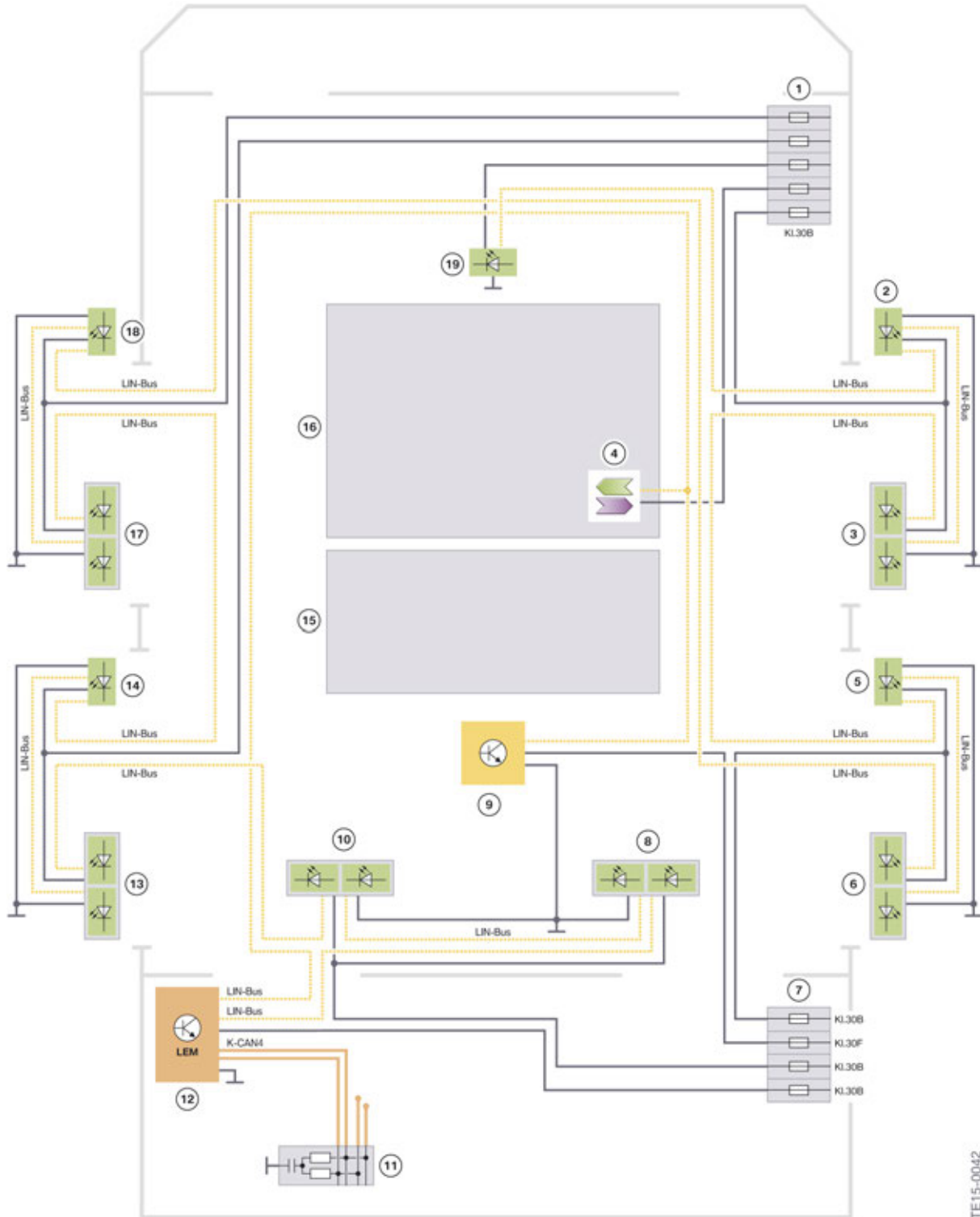

TE15-0042

Light Effect Manager

G12 General Vehicle Electronics

2. Interior Lights

Index	Explanation
1	Fuses in the power distribution box, front right
2	Lighting for tweeter cover, passenger's side door
3	Lighting for mid-range speaker cover, passenger's side door
4	Supply for ambient lighting, panorama glass roof
5	Light saber, passenger's side
6	Lighting for mid-range speaker cover, rear passenger's side door
7	Fuses in the power distribution box, rear right
8	Lighting for tweeter cover on right storage shelf
9	Touch Command
10	Lighting for tweeter cover on left storage shelf
11	CAN terminator
12	Light Effect Manager (LEM)
13	Lighting for tweeter cover, rear driver's side door
14	Light saber, driver's side
15	Panorama glass roof, rear
16	Panorama glass roof, front
17	Lighting for mid-range speaker cover, driver's side door
18	Lighting for tweeter cover, driver's side door
19	Lighting for center speaker

LED modules are used for the speaker cover lighting.

White LEDs are used for the light saber lighting.

The lighting of the panorama glass roof is accomplished using LEDs.

The lighting is controlled via 2 local LIN-buses:

- LIN-bus from Light Effect Manager to the panorama glass roof and Touch Command
- LIN-bus from Light Effect Manager to the light sabers and to the LED modules of the speaker covers

G12 General Vehicle Electronics

2. Interior Lights

2.3.2. System components

Light Effect Manager



Light Effect Manager

The control unit Light Effect Manager (LEM) is responsible for controlling the following lighting:

- Panorama glass roof
- Light sabers at the B-pillars of the G12
- Speaker covers in the High End audio system
- Touch Command snap-in adaptor

Panorama glass roof

The ambient lighting of the interior is extended to the panorama glass roof. This creates a high-quality roof appearance for journeys at night.

The light colors are coupled with the colors of the ambient lighting of the vehicle interior. The lighting of the panorama glass roof can be dimmed separately.

Function

The light is fed into the window glass by means of LED modules and fiber optic conductors installed at the sides. The light is refracted at the printed graphic and diverted into the interior.

G12 General Vehicle Electronics

2. Interior Lights

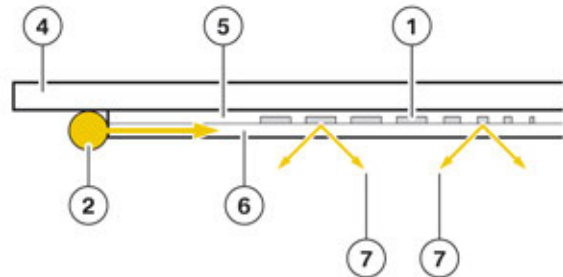
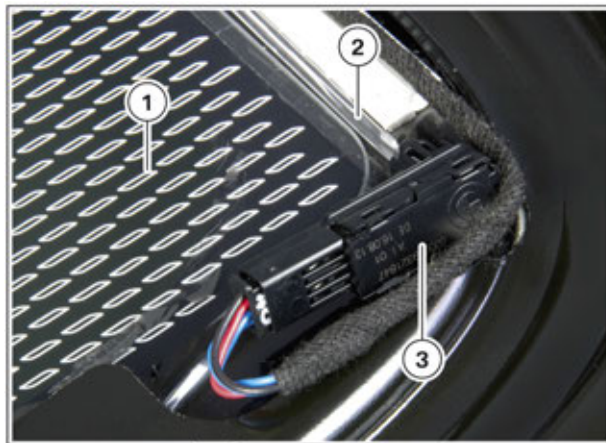

TE15-0451

Operating principle of panorama glass roof lighting

Index	Explanation
1	Printed graphic
2	Fiber-optic conductor
3	LED
4	Outer, tinted glass pane
5	Foil
6	Inner glass pane
7	Visible light in the vehicle interior

G12 General Vehicle Electronics

2. Interior Lights

Light saber

The two light sabers are installed in the rear doors and are illuminated white. The light sabers can be dimmed and switched off only as a pair.

Operation is possible via:

- Controller
- Rear Seat Entertainment system
- Capacitive sensors on the light sabers

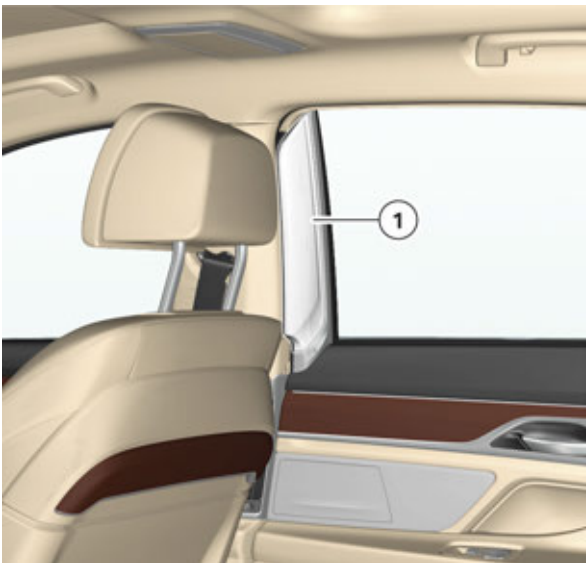

Light saber

Index	Explanation
1	Light saber

Speaker covers for High End audio system

The lighting of the tweeter covers is controlled via the Light Effect Manager.

G12 General Vehicle Electronics

3. Washer/wiper System

3.1. System wiring diagram

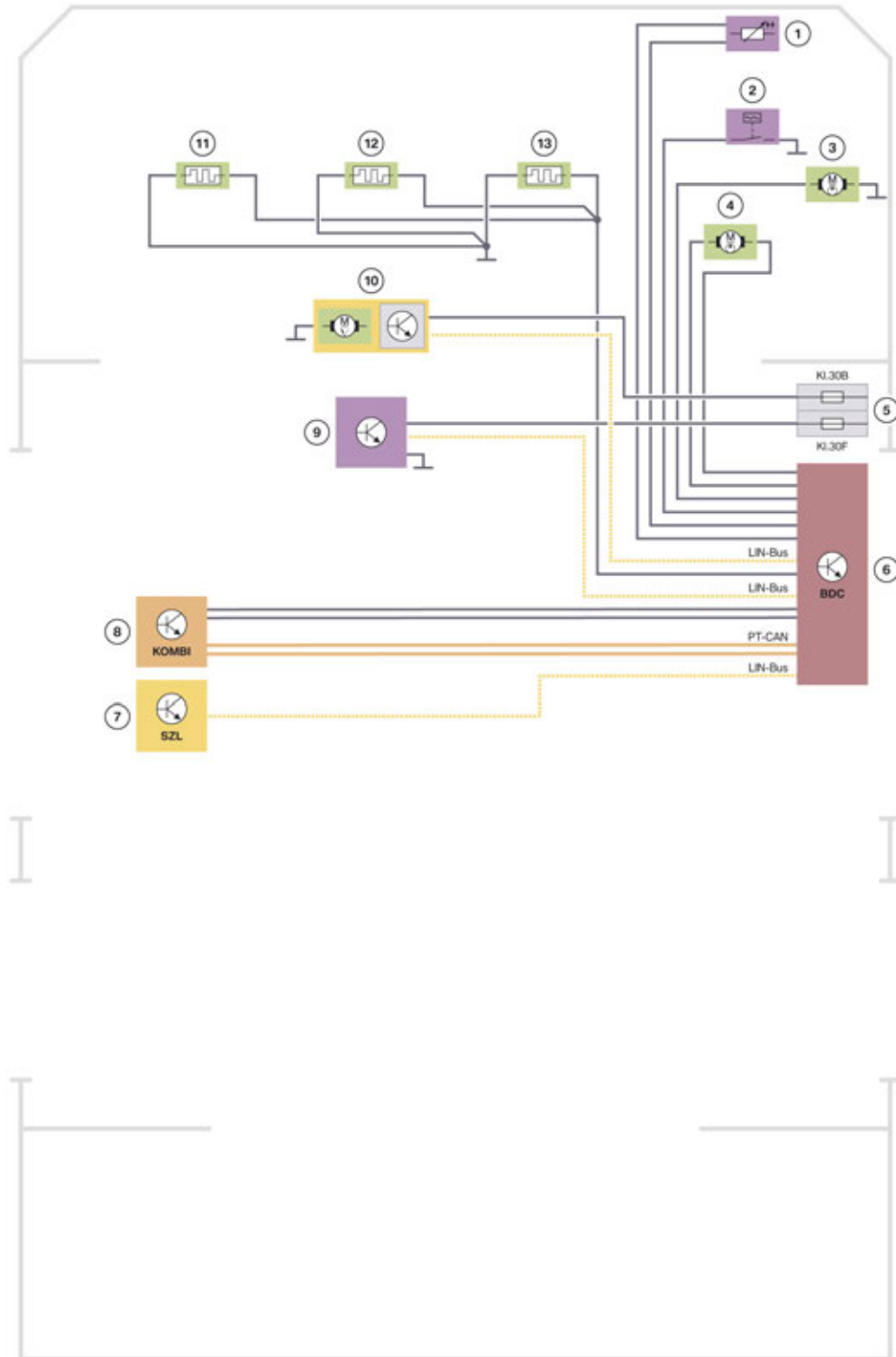

Washer/wiper system

TE14-1222

G12 General Vehicle Electronics

3. Washer/wiper System

Index	Explanation
1	Outside temperature sensor
2	Washer fluid level switch
3	Washer pump for headlight cleaning system
4	Electric motor, windscreen washer pump
5	Fuses in the power distribution box, front right
6	Body Domain Controller (BDC)
7	Steering column switch cluster (SZL)
8	Instrument cluster (KOMBI)
9	Rain-light-solar-condensation sensor
10	Wiper motor
11	Heated washer jet, left
12	Heated washer jet, center
13	Heated washer jet, right

The wiper motor is a 12 V motor with a transmission. The control unit, the wiper motor and the transmission form one replaceable unit. This wiper motor unit comprises:

- A permanent magnet, direct current motor with attached reduction gear
- Control unit electronics with eccentric shaft sensor and suppressor components with attached plug connection

The control unit in the wiper motor is able to identify the following faults:

- Faults in the control unit electronics
- Short circuits at the motor and sensor system
- Open lines at the motor and sensor system

The control unit in the wiper motor does not have a fault memory. The fault code entry is stored in the Body Domain Controller (BDC).

The heated washer jets are activated by the Body Domain Controller.

The Body Domain Controller is also responsible for activation of the windscreen washer pump and evaluation of the washer fluid level switch.

G12 General Vehicle Electronics

4. Locking and Security Functions

4.1. Comfort Access

4.1.1. System wiring diagram

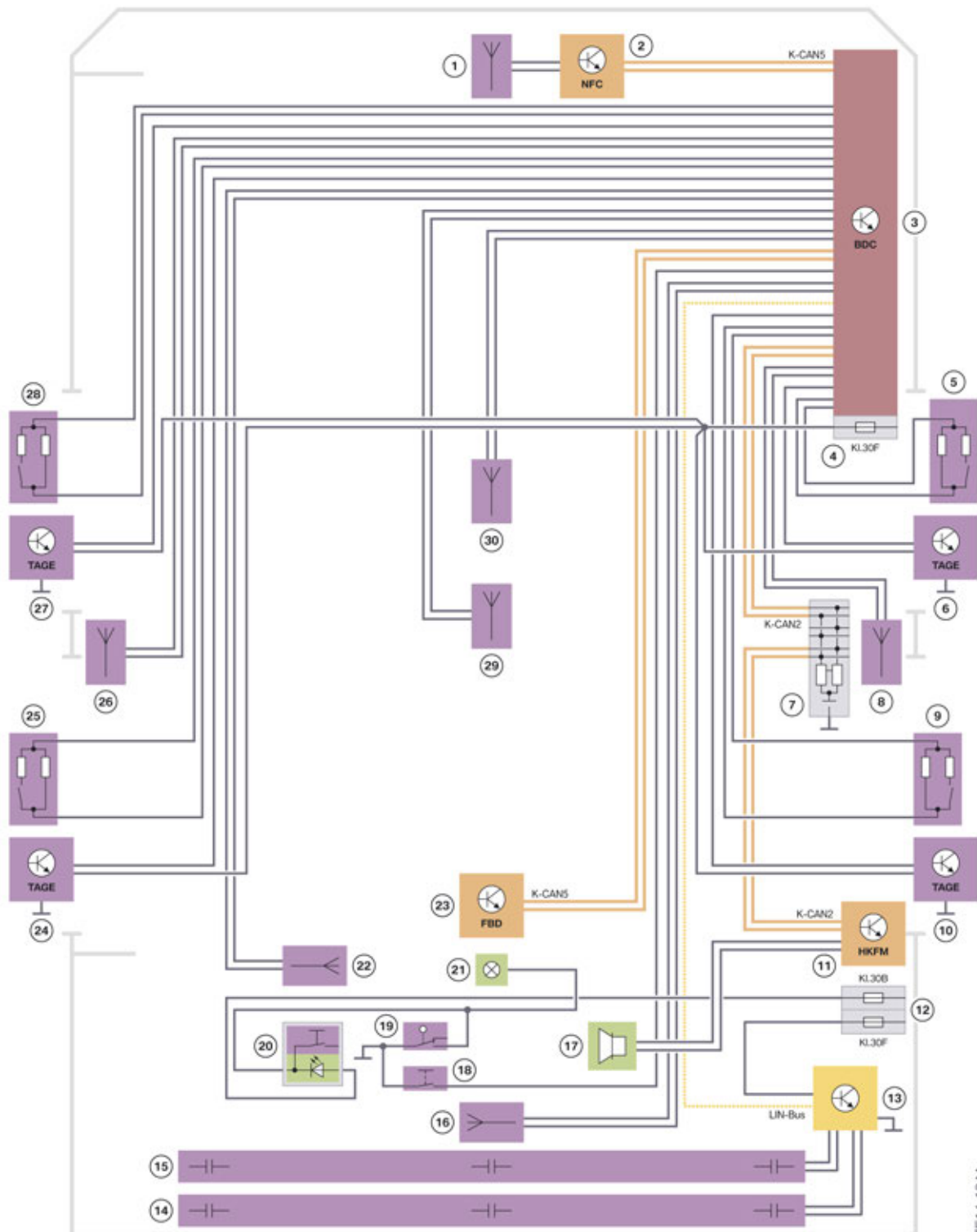

G12 General Vehicle Electronics

4. Locking and Security Functions

Index	Explanation
1	Aerial, Near Field Communication
2	Control unit, Near Field Communication (NFC)
3	Body Domain Controller (BDC)
4	Fuse in the Body Domain Controller
5	Switch in door lock of front passenger door
6	Outside door handle electronics (TAGE), front passenger door
7	CAN terminator
8	Comfort Access aerial, side sill, right
9	Switch in door lock of rear passenger door
10	Outside door handle electronics (TAGE), rear passenger door
11	Tailgate function module (HKFM)
12	Fuses in the power distribution box, rear right
13	Control unit for contactless rear lid opening
14	Sensor at bottom for non-contact tailgate opening
15	Sensor at top for non-contact tailgate opening
16	Comfort Access aerial, bumper, rear
17	Acoustic warning device for tailgate activation
18	Button for tailgate
19	Tailgate contact switch in the tailgate lock
20	Button for closing tailgate
21	Luggage compartment light
22	Comfort Access aerial, luggage compartment
23	Remote control receiver (FBD)
24	Outside door handle electronics (TAGE), rear driver's side door
25	Outside door handle electronics (TAGE), rear driver's side door
25	Switch in door lock of rear driver's side door
26	Comfort Access aerial, side sill, left
27	Outside door handle electronics (TAGE), driver's door
28	Switch in door lock of driver's door
29	Comfort Access aerial, passenger compartment
30	Comfort Access aerial, passenger compartment

G12 General Vehicle Electronics

4. Locking and Security Functions

4.2. Central locking system

4.2.1. System wiring diagram

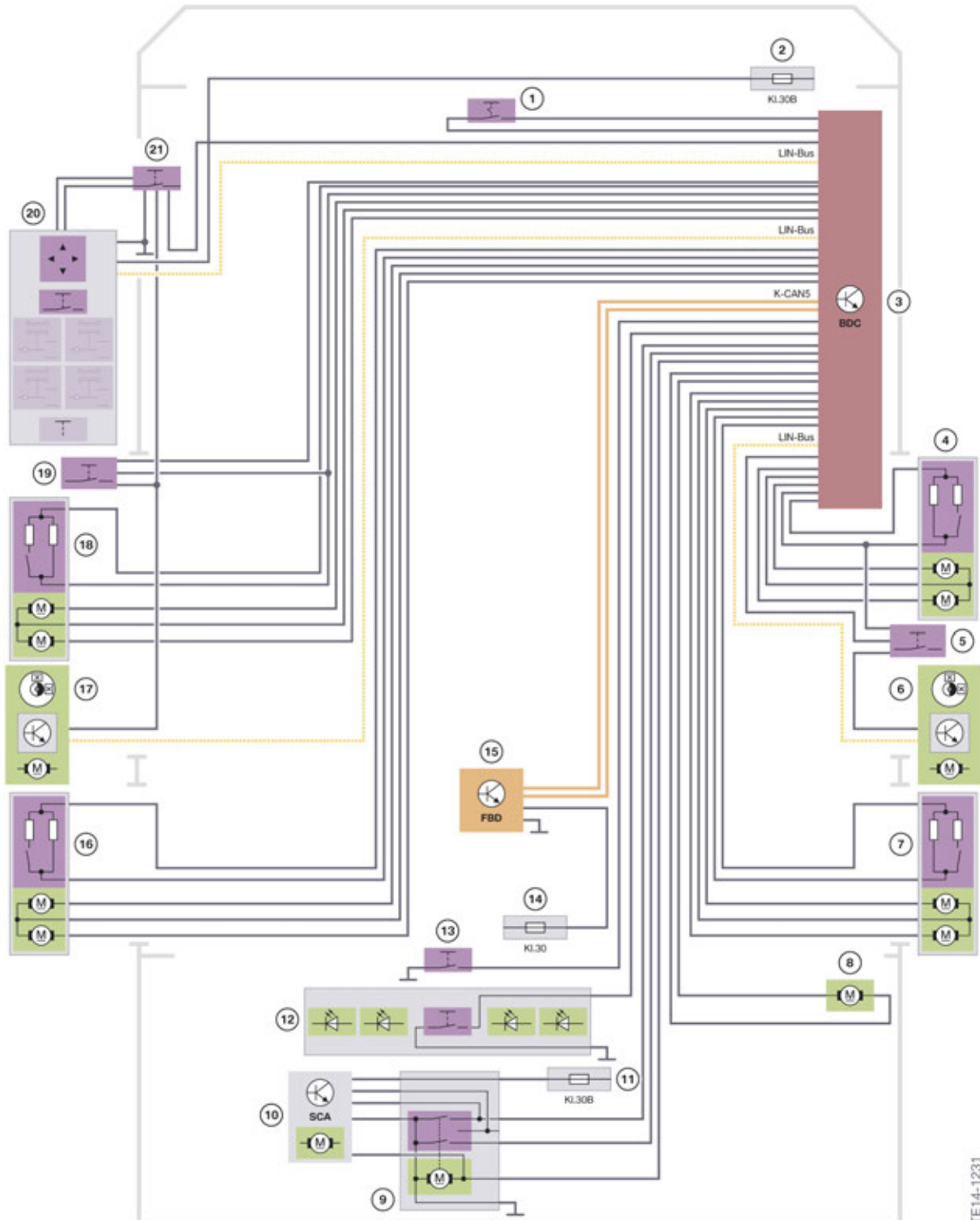

Central locking system

TE14-1231

G12 General Vehicle Electronics

4. Locking and Security Functions

Index	Explanation
1	Valet position switch
2	Fuse in the power distribution box, front right
3	Body Domain Controller (BDC)
4	Door lock, front passenger door
5	Central locking button, front passenger door
6	Power window electronics, passenger's side front
7	Door lock, passenger's side, rear
8	Servodrive for fuel filler flap
9	Tailgate contact switch in the tailgate lock
10	Automatic Soft Close drive
11	Fuse in the rear power distribution box
12	Number plate light strip with button for tailgate
13	Button for closing tailgate
14	Fuse in the rear power distribution box
15	Remote control receiver (FBD)
16	Door lock, driver's side, rear
17	Power window electronics, driver's side front
18	Door lock, driver's door
19	Central locking button, driver's door
20	Switch block, driver's door
21	Button for opening tailgate

4.2.2. Function

The function of the central locking system of the G12 is based on that of current BMW models. All functions relevant for the central locking system are controlled by the Body Domain Controller. The function is as follows:

- The radio signal from the ID transmitter is received by the remote control receiver.
- The signal causes the BDC to activate the central locking system and the interior lighting.
- The BDC evaluates the status of all door contacts, the tailgate and valet position switch.
- The status of the central locking system button is also evaluated by the BDC. The BDC activates the central locking system, depending on the status.
- The BDC is responsible for activation of the central locking system and the drive for automatic soft-close in the tailgate.
- Activation of fuel filler flap unlocking is also performed by the BDC.

G12 General Vehicle Electronics

4. Locking and Security Functions

4.3. Automatic operation of tailgate

4.3.1. System wiring diagram

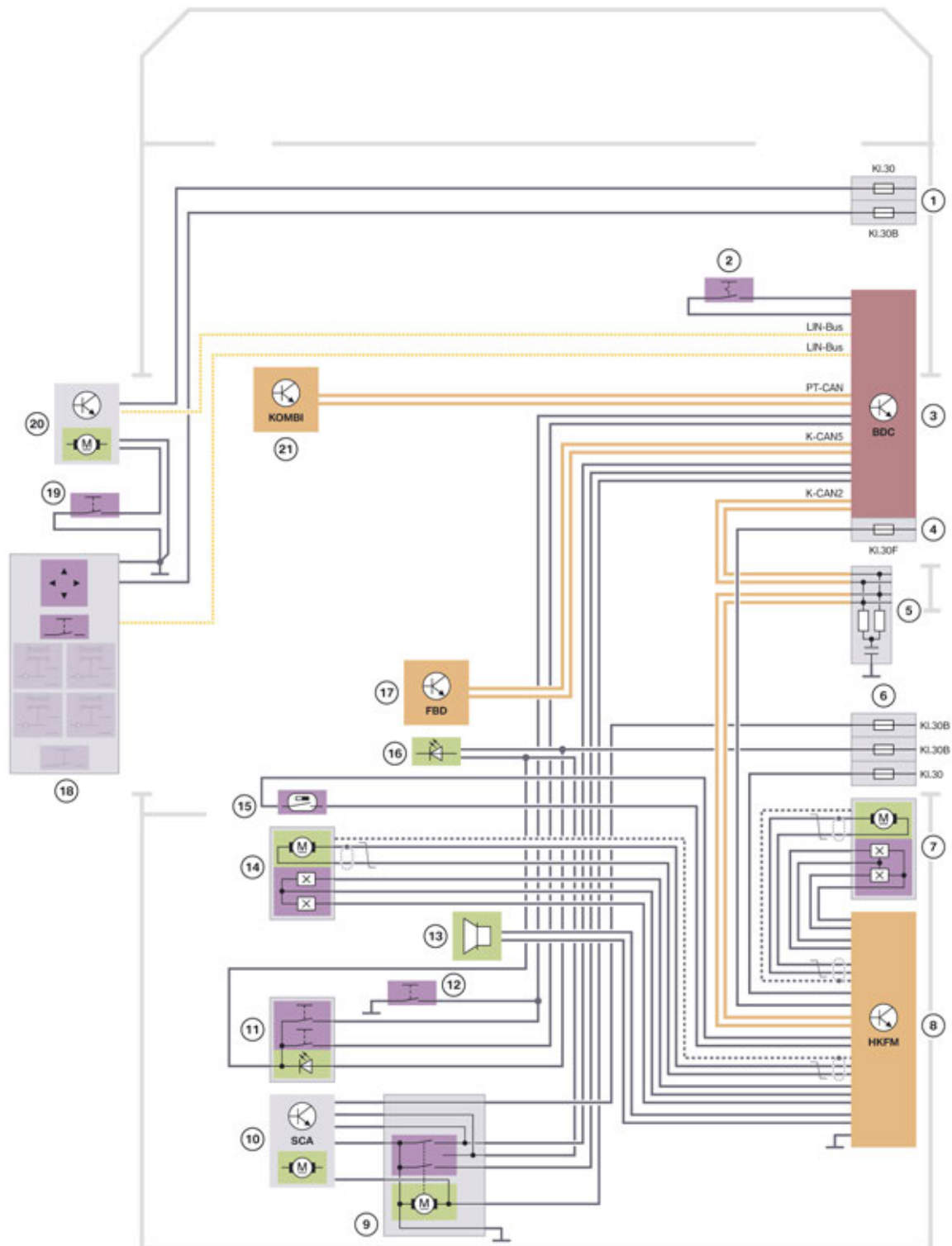

Automatic operation of tailgate

G12 General Vehicle Electronics

4. Locking and Security Functions

Index	Explanation
1	Fuses in the power distribution box, front right
2	Valet position switch
3	Body Domain Controller (BDC)
4	Fuse in the Body Domain Controller
5	CAN terminator
6	Fuses in the rear power distribution box
7	Tailgate lift drive, right
8	Tailgate function module (HKFM)
9	Tailgate contact switch in the tailgate lock
10	Automatic Soft Close drive
11	Button for closing tailgate (inner)
12	Button for tailgate
13	Acoustic warning device for tailgate activation
14	Tailgate lift drive, left
15	Reed contact
16	Luggage compartment light
17	Remote control receiver (FBD)
18	Switch block, driver's door
19	Button for opening tailgate
20	Power window motor, driver's side front
21	Instrument cluster (KOMBI)

G12 General Vehicle Electronics

4. Locking and Security Functions

4.4. Automatic Soft Close system

4.4.1. System wiring diagram

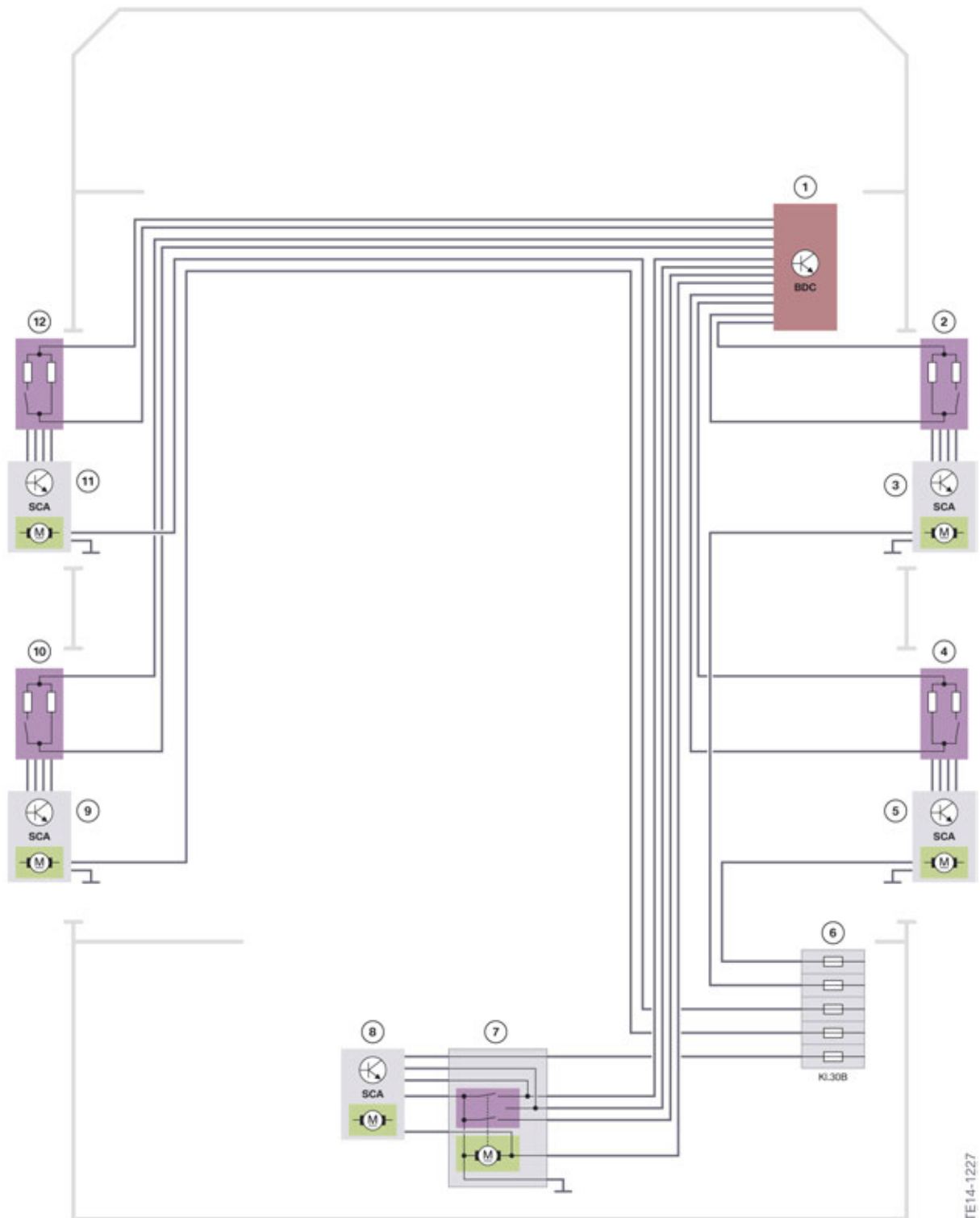

Automatic Soft Close system

TE14-1227

G12 General Vehicle Electronics

4. Locking and Security Functions

Index	Explanation
1	Body Domain Controller (BDC)
2	Switch in door lock of front passenger door
3	Automatic Soft Close drive, front passenger door
4	Switch in door lock of rear passenger door
5	Automatic Soft Close drive, rear passenger door
6	Fuses in the power distribution box, rear right
7	Tailgate contact switch in the tailgate lock
8	Automatic Soft Close drive, tailgate
9	Automatic Soft Close drive, rear driver's-side door
10	Switch in door lock of rear driver's side door
11	Automatic Soft Close drive, driver's door
12	Switch in door lock of driver's door

G12 General Vehicle Electronics

5. Alarm System

5.1. System wiring diagram

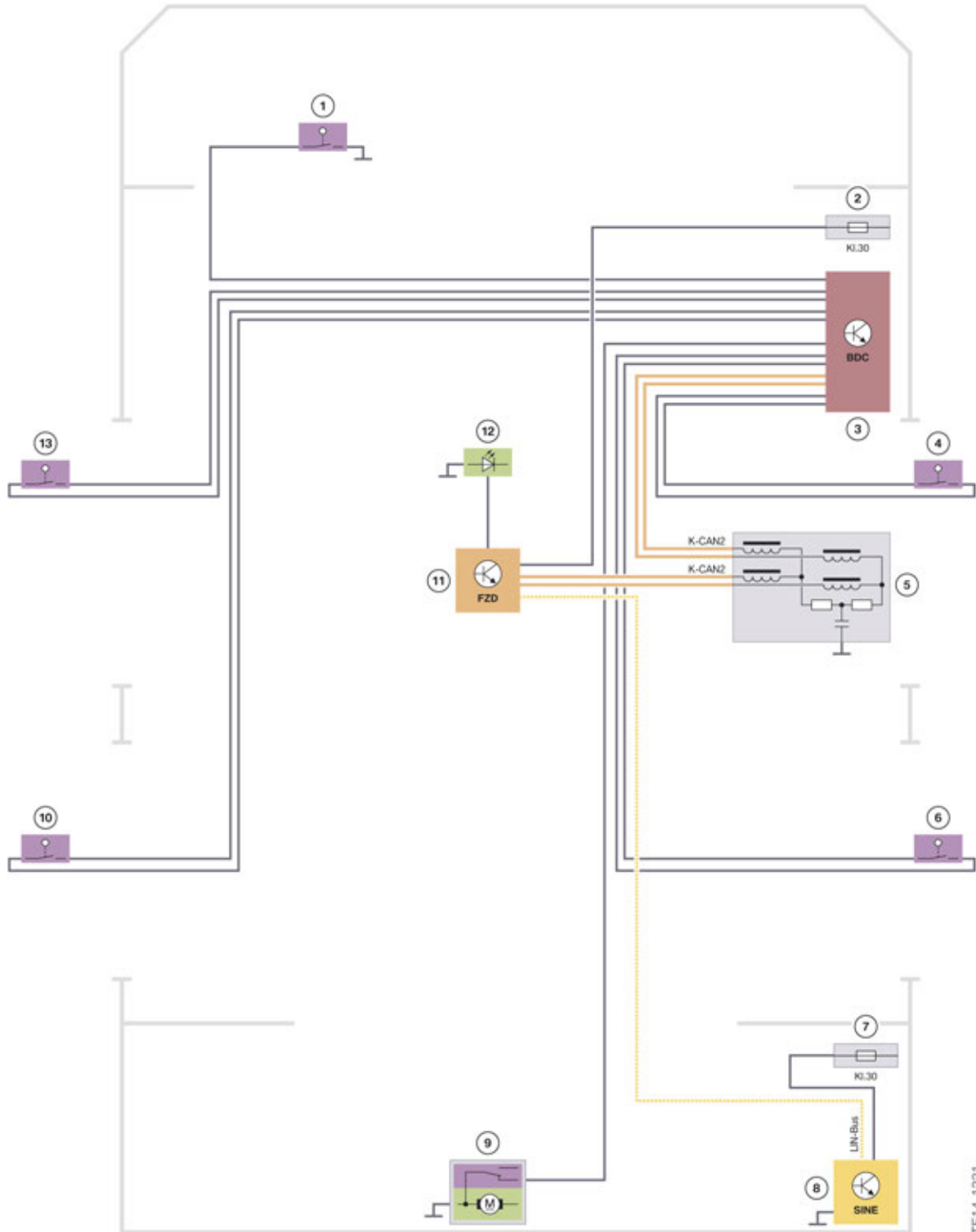

Alarm system

TE14-1221

G12 General Vehicle Electronics

5. Alarm System

Index	Explanation
1	Engine compartment lid contact switch
2	Fuse in the power distribution box, front right
3	Body Domain Controller (BDC)
4	Door contact, front passenger side, front
5	CAN terminator
6	Door contact on front passenger side, rear
7	Fuse in the power distribution box, rear right
8	Siren with tilt alarm sensor
9	Tailgate contact switch in the tailgate lock
10	Door contact on driver's side, rear
11	Roof function center (FZD)
12	LED in the interior mirror
13	Door contact, driver's side, front

The alarm system in the G12 is equipped with an ultrasonic interior movement detector for monitoring the passenger compartment. The ultrasonic interior movement detector (USIS) is fully integrated in the roof function center (FZD).

The door contacts, engine compartment lid contact switch and the opening of the tailgate are monitored by the Body Domain Controller. As soon as a status changes, the ultrasonic interior movement detector receives this information via the K-CAN2. If the alarm system is activated, the siren with tilt alarm sensor is activated by the control unit in the event of a break-in.

The SINE is connected to the FZD via a local interconnect network bus.

The status of the alarm system is displayed via the LED at the interior mirror.

G12 General Vehicle Electronics

6. Power Window Regulator

6.1. System wiring diagram

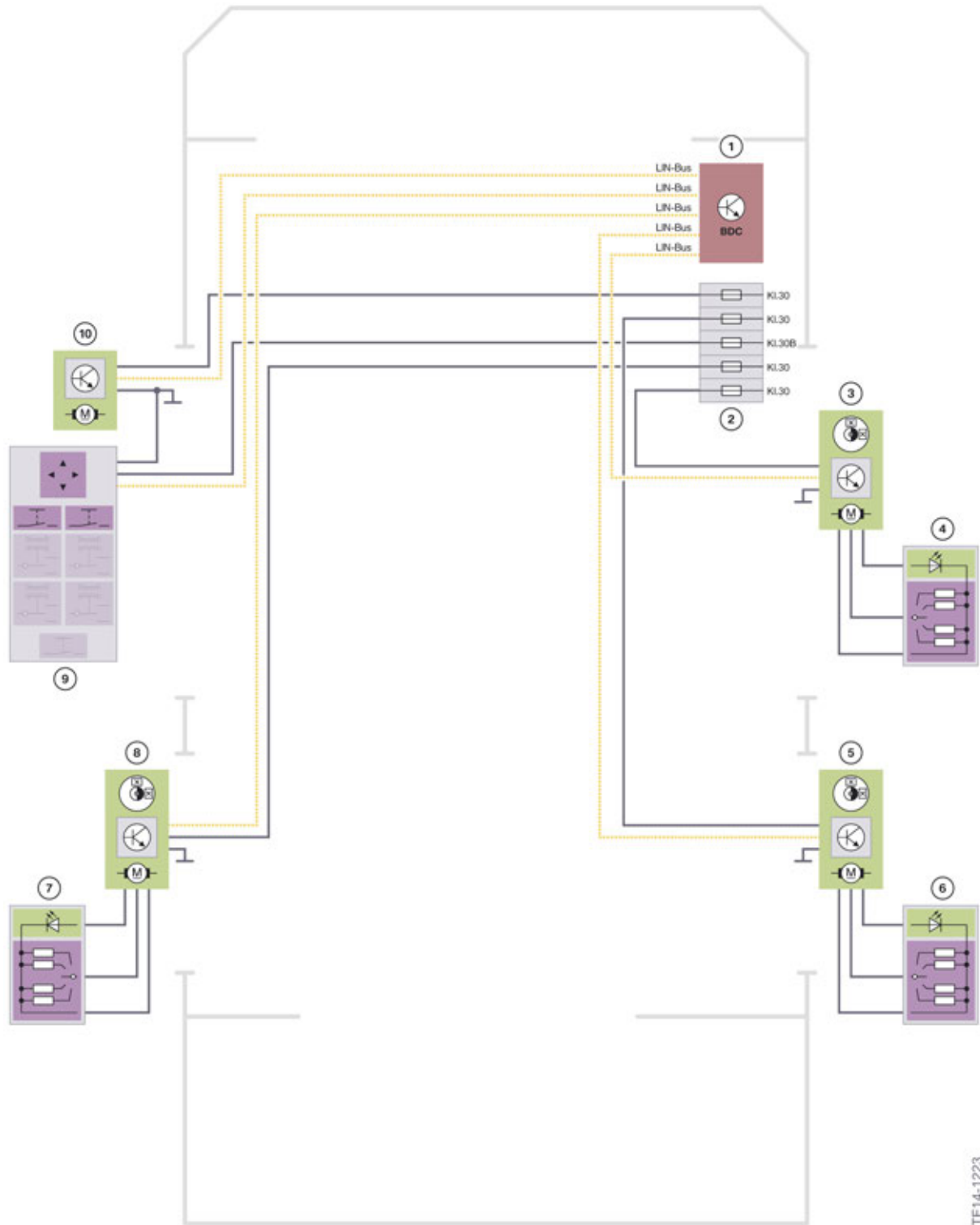

Power window regulator

TE14-1223

G12 General Vehicle Electronics

6. Power Window Regulator

Index	Explanation
1	Body Domain Controller (BDC)
2	Fuses in the power distribution box, front right
3	Power window motor, passenger's side
4	Power window switch, front passenger side, front
5	Power window motor, passenger's side rear
6	Power window switch, front passenger side rear
7	Power window switch driver's side, rear
8	Power window motor, driver's side rear
9	Switch block, driver's door
10	Power window motor, driver's side front

G12 General Vehicle Electronics

7. Slide/Tilt Sunroof

7.1. System wiring diagram

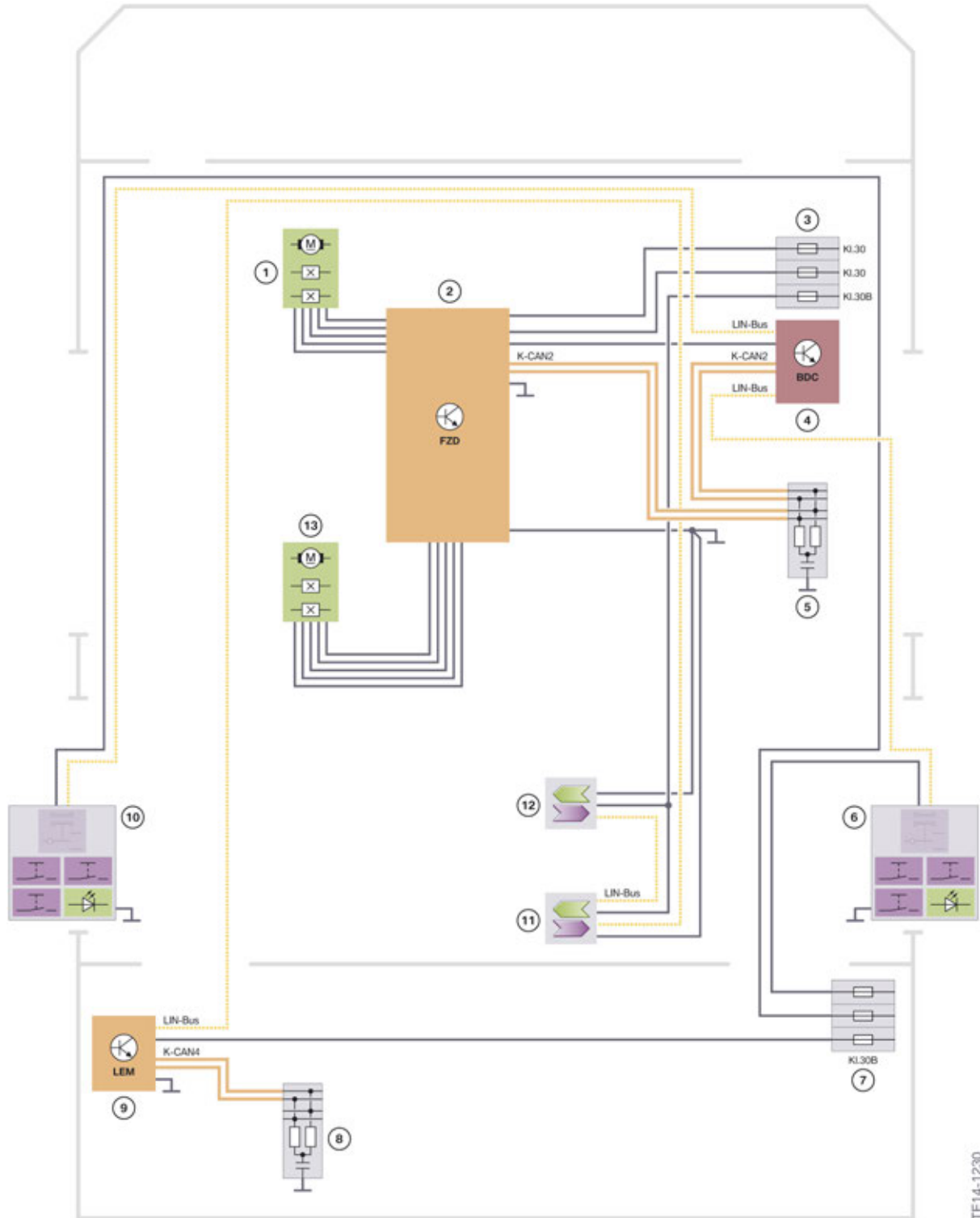

Slide/Tilt sunroof

TE14-1230

G12 General Vehicle Electronics

7. Slide/Tilt Sunroof

Index	Explanation
1	Motor, slide/tilt sunroof
2	Roof function center (FZD)
3	Fuses in the power distribution box, front right
4	Body Domain Controller (BDC)
5	CAN terminator
6	Switch block, rear door, right
7	Fuses in the power distribution box, rear right
8	CAN terminator
9	Light Effect Manager (LEM)
10	Switch block, rear door, left
11	Supply for ambient lighting, rear panorama glass roof
12	Supply for ambient lighting, front panorama glass roof
13	Sliding sunshade motor

G12 General Vehicle Electronics

8. Roller Sunblind

8.1. System wiring diagram

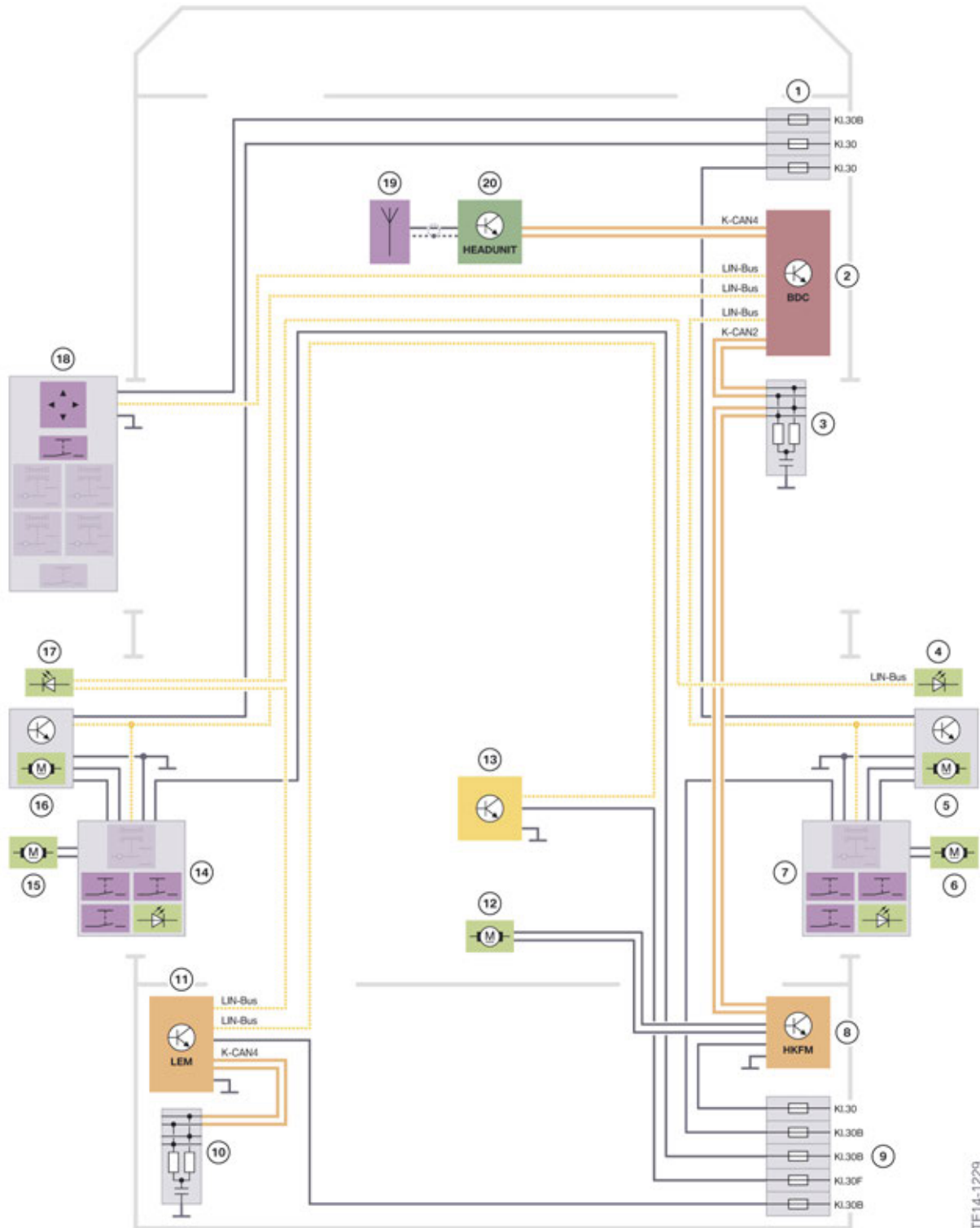

Roller sunblind

TE14-1229

G12 General Vehicle Electronics

8. Roller Sunblind

Index	Explanation
1	Fuses in the power distribution box, front right
2	Body Domain Controller (BDC)
3	CAN terminator
4	Light saber, passenger's side
5	Power window electronics, passenger's side rear
6	Drive for roller sunblind, passenger's side rear
7	Switch for roller sunblind
8	Tailgate function module (HKFM)
9	Fuses in the power distribution box, rear right
10	CAN terminator
11	Light Effect Manager (LEM)
12	Roller sunblind rive, rear window
13	BMW Touch Command
14	Switch for roller sunblind
15	Drive for roller sunblind, driver's side rear
16	Power window electronics, driver's side rear
17	Light saber, driver's side
18	Switch block, driver's door
19	WLAN aerial
20	Head unit

G12 General Vehicle Electronics

9. Steering Column Switch Cluster

9.1. System wiring diagram

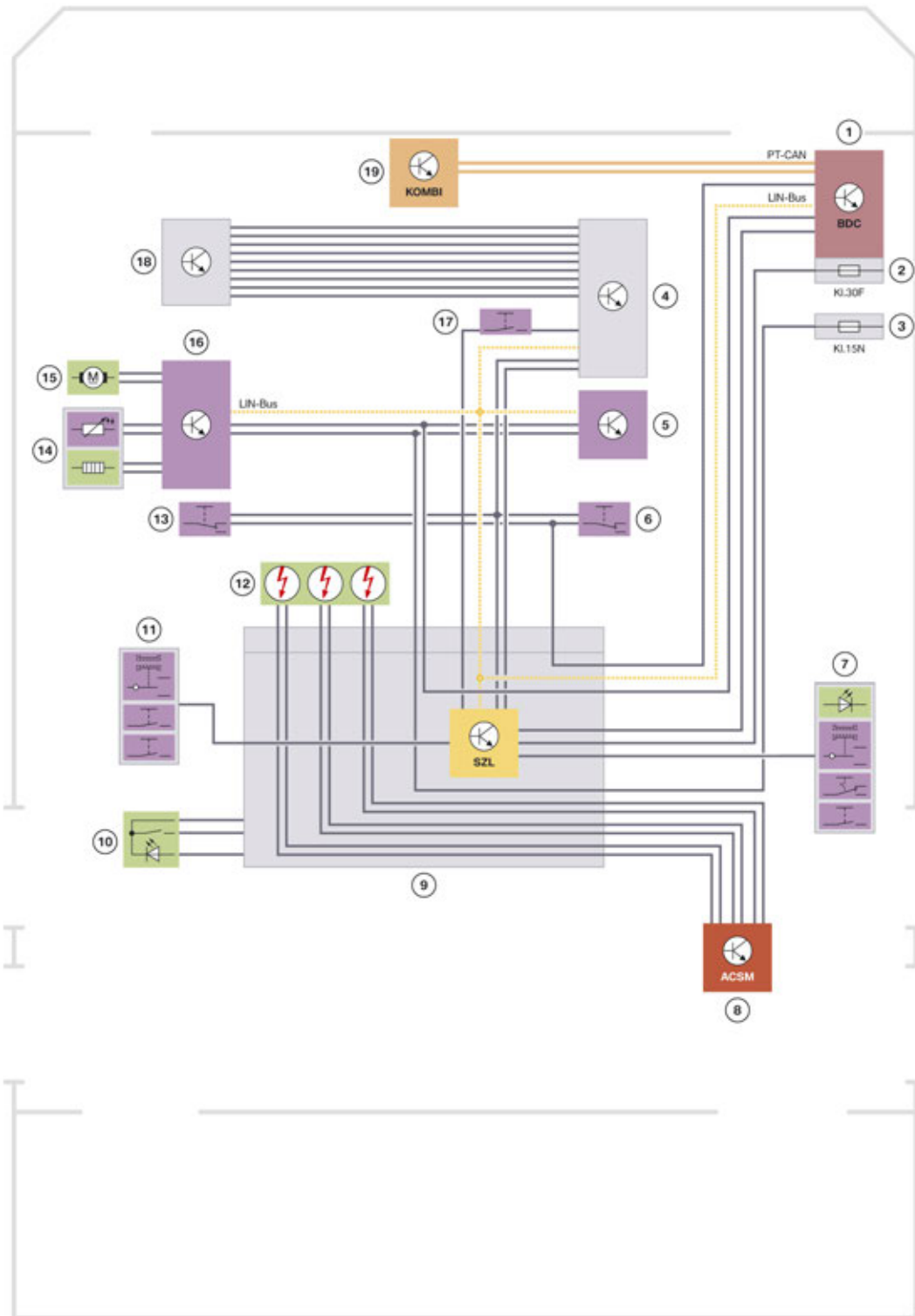

Steering column switch cluster

TE14-1243

G12 General Vehicle Electronics

9. Steering Column Switch Cluster

Index	Explanation
1	Body Domain Controller (BDC)
2	Fuse in the Body Domain Controller
3	Fuse in the power distribution box, front right
4	Multifunction steering wheel buttons, right
5	Touch detection HOD (Hands Off Detection)
6	Shift paddle, right
7	Drop arm, right
8	Advanced Crash Safety Module (ACSM)
9	Steering column switch cluster (SZL)
10	Steering-wheel heating button
11	Drop arm, left
12	Driver's airbag
13	Shift paddle, left
14	Steering wheel heating
15	Vibration motor
16	Steering wheel module
17	Horn button
18	Multifunction steering wheel buttons, left
19	Instrument cluster (KOMBI)

All signals of the buttons and switches of the multifunction steering wheel (MFL) and the steering column switch cluster (SZL) are transmitted via Local Interconnect Network to the Body Domain Controller (BDC).

G12 General Vehicle Electronics

10. Steering Column Adjustment

10.1. System wiring diagram

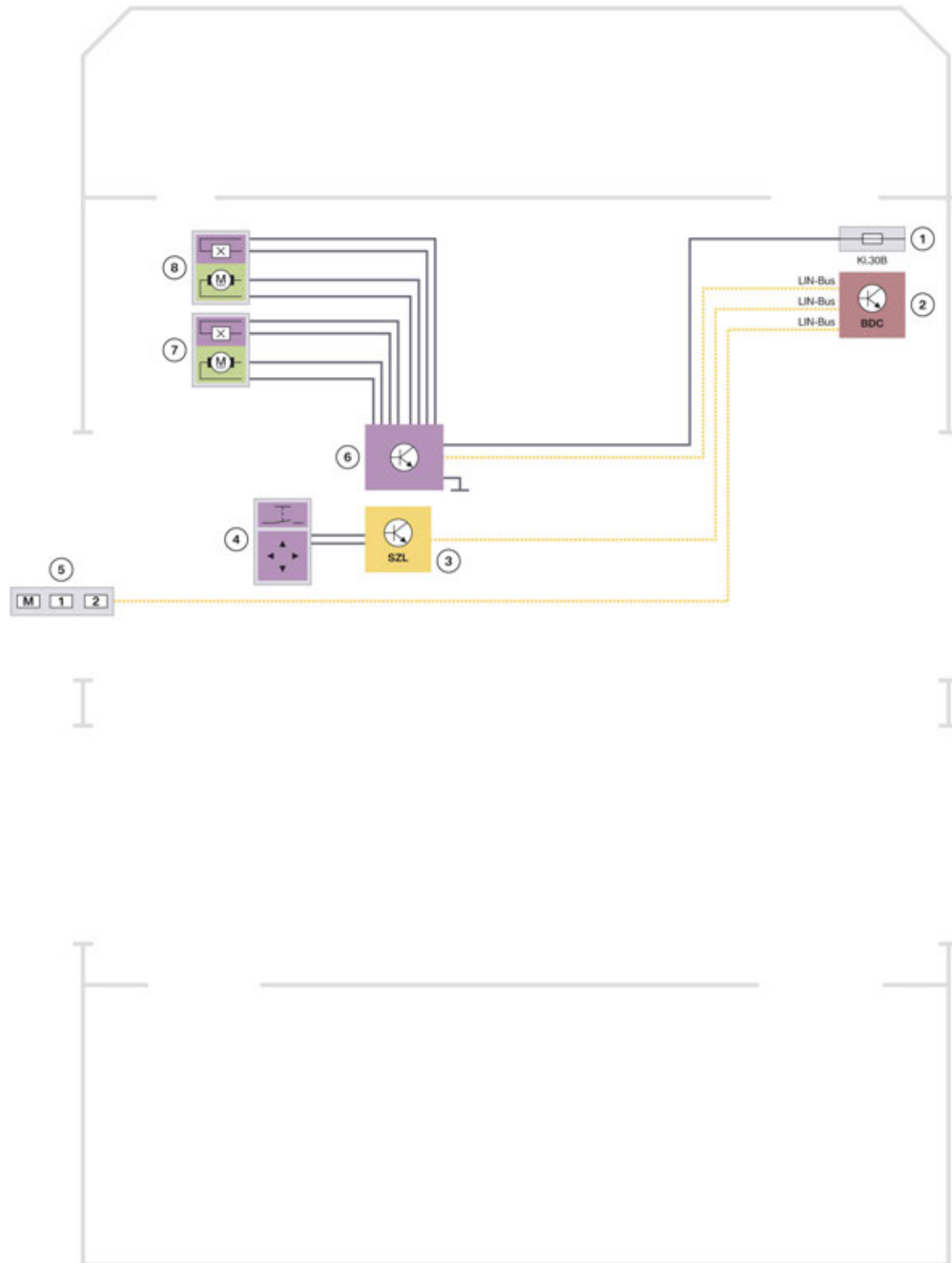

Steering column adjustment

TE14-1242

G12 General Vehicle Electronics

10. Steering Column Adjustment

Index	Explanation
1	Fuse in the power distribution box, front right
2	Body Domain Controller (BDC)
3	Steering column switch cluster (SZL)
4	Button for steering column adjustment
5	Memory switch
6	Electronics for steering column adjustment
7	Motor for steering column adjustment, height
8	Motor for steering column adjustment, vertical

G12 General Vehicle Electronics

11. Exterior Mirrors

11.1. Exterior mirror, basic version

11.1.1. System wiring diagram

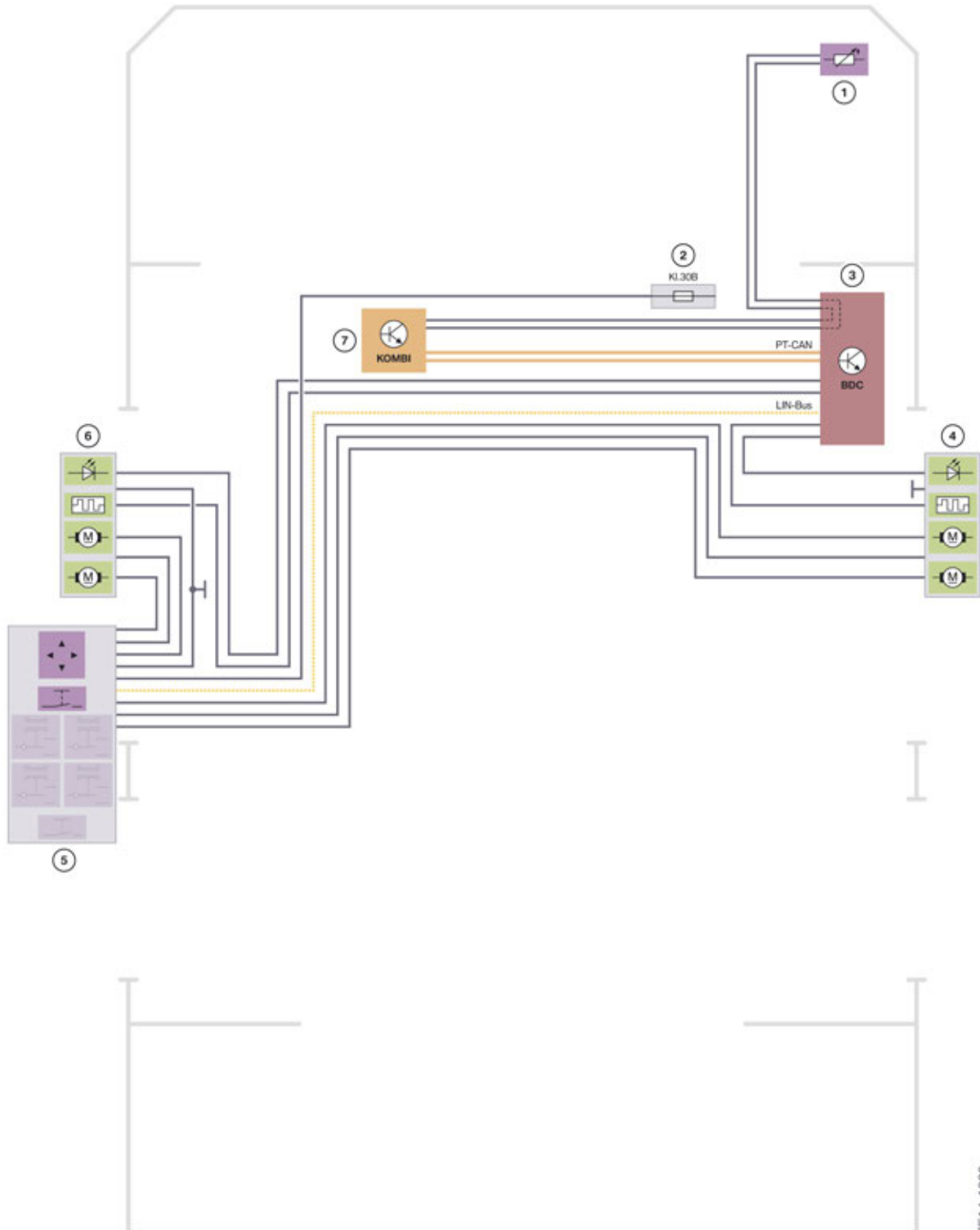

Exterior mirror, basic version

G12 General Vehicle Electronics

11. Exterior Mirrors

Index	Explanation
1	Outside temperature sensor
2	Fuse in the power distribution box, front right
3	Body Domain Controller (BDC)
4	Exterior mirror, front passenger side
5	Switch block, driver's door
6	Exterior mirror, driver's side
7	Instrument cluster (KOMBI)

The electric motors of the exterior mirror are activated directly using the mirror adjustment switch.

G12 General Vehicle Electronics

11. Exterior Mirrors

11.2. Exterior mirror High

11.2.1. System wiring diagram

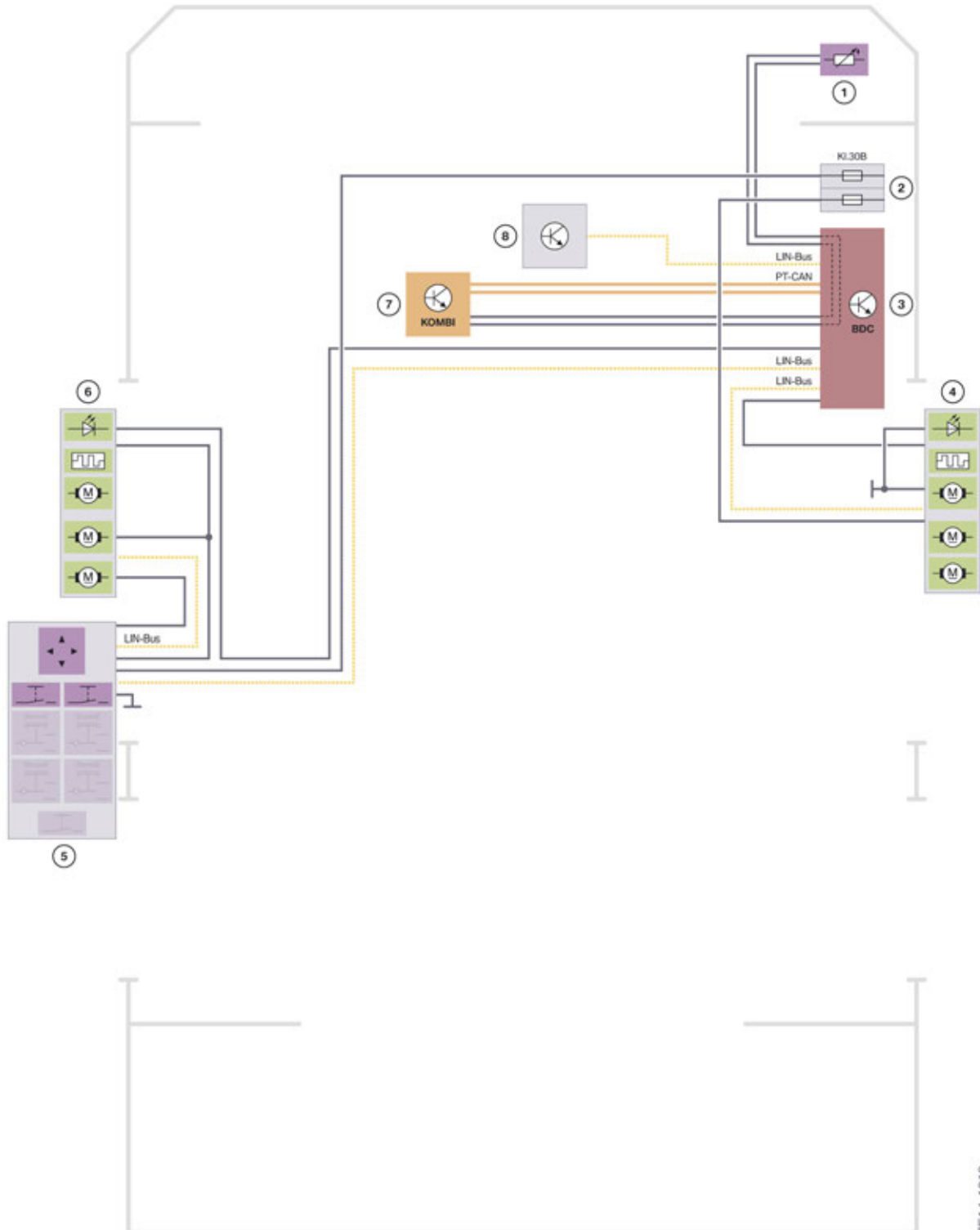

G12 General Vehicle Electronics

11. Exterior Mirrors

Index	Explanation
1	Outside temperature sensor
2	Fuses in the power distribution box, front right
3	Body Domain Controller (BDC)
4	Exterior mirror, front passenger side
5	Switch block, driver's door
6	Exterior mirror, driver's side
7	Instrument cluster (KOMBI)
8	Inside mirror

The instrument cluster receives the value of the ambient temperature from the outside temperature sensor and makes this available via the PT-CAN. The Body Domain Controller evaluates the signal and triggers the activation of the mirror heating via the local interconnect network bus. The control of the heater output is dependent on the ambient temperature and the switch position of the driving experience switch.

The mirror servomotors are activated by the mirror electronics. The request for adjusting the exterior mirror is received by the mirror electronics via the local interconnect network bus.

G12 General Vehicle Electronics

12. Inside Mirror

12.1. System wiring diagram

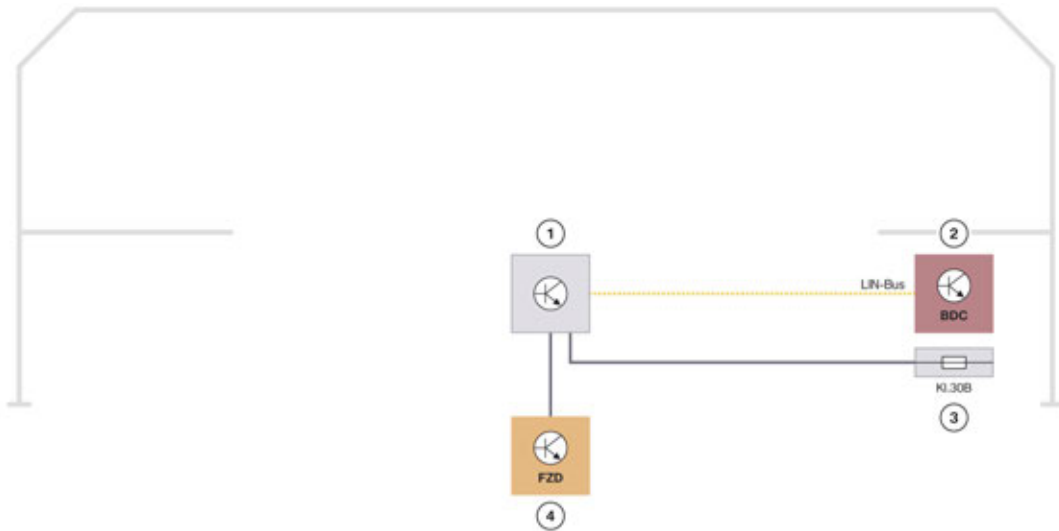

TE15-0038

Inside mirror

Index	Explanation
1	Inside mirror
2	Body Domain Controller (BDC)
3	Fuse in the power distribution box, front right
4	Roof function center (FZD)

The interior mirror is connected with the Body Domain Controller via LIN-bus.

The LED for the alarm system is located at the interior mirror.

G12 General Vehicle Electronics

13. Seats

13.1. Front seats

13.1.1. Memory seat, front, driver's side

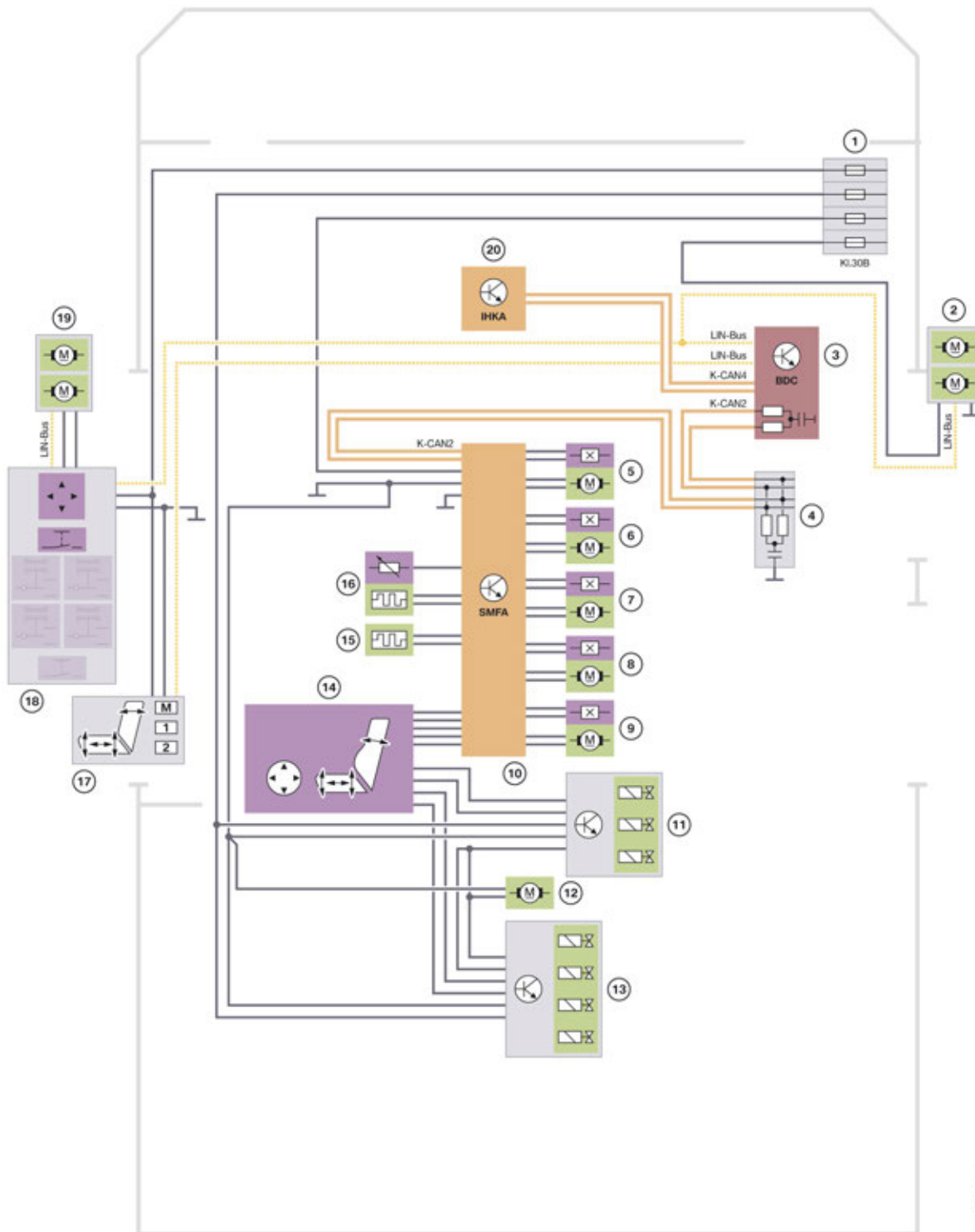

TE14-1249

G12 General Vehicle Electronics

13. Seats

Index	Explanation
1	Fuses in the power distribution box, front right
2	Exterior mirror, front passenger side
3	Body Domain Controller (BDC)
4	CAN terminator
5	Electric motor, forward/back seat adjustment
6	Electric motor, seat angle adjustment
7	Electric motor, seat height adjustment
8	Electric motor, backrest angle adjustment
9	Motor, head restraint height adjustment
10	Driver's seat module (SMFA)
11	Valve block, backrest width adjustment
12	Lumbar support pump
13	Valve block, lumbar support adjustment
14	Switch, seat adjustment
15	Seat heating pad, backrest
16	Seat heating pad, seat surface
17	Memory switch
18	Switch block, driver's door
19	Exterior mirror, driver's side
20	Integrated automatic heating / air conditioning (IHKA)

G12 General Vehicle Electronics

13. Seats

13.1.2. Memory seat, front, passenger's side

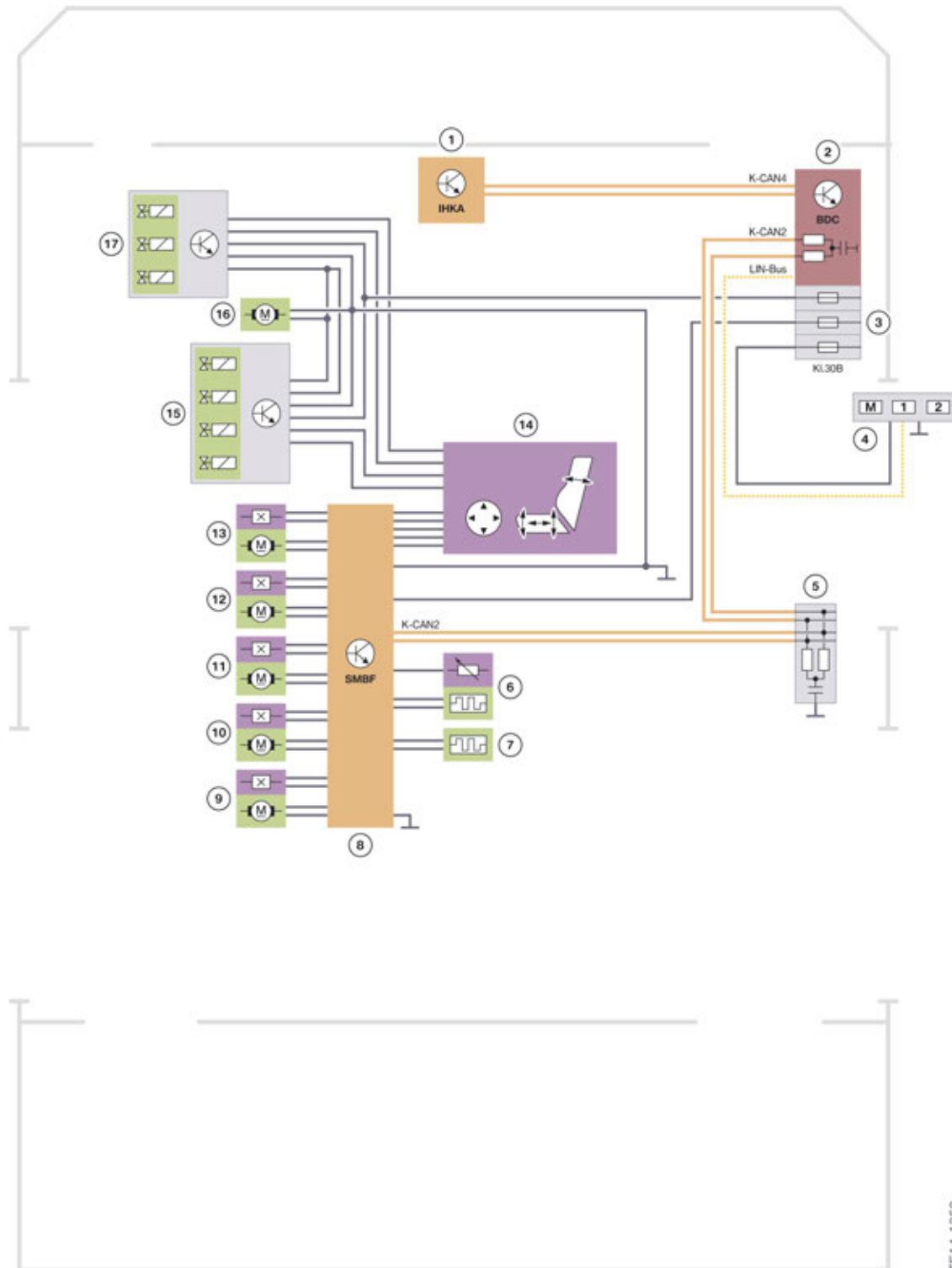

Memory seat, front, passenger's side

TE14-1250

G12 General Vehicle Electronics

13. Seats

Index	Explanation
1	Integrated automatic heating / air conditioning (IHKA)
2	Body Domain Controller (BDC)
3	Fuses in the power distribution box, front right
4	Memory switch
5	CAN terminator
6	Seat heating pad, seat surface
7	Seat heating pad, backrest
8	Front passenger seat module, (SMBF)
9	Motor, head restraint height adjustment
10	Electric motor, forward/back seat adjustment
11	Electric motor, seat angle adjustment
12	Electric motor, seat height adjustment
13	Electric motor, backrest angle adjustment
14	Switch, seat adjustment
15	Valve block, lumbar support adjustment
16	Lumbar support pump
17	Valve block, backrest width adjustment

G12 General Vehicle Electronics

13. Seats

13.1.3. Multifunction seat, front, driver's side

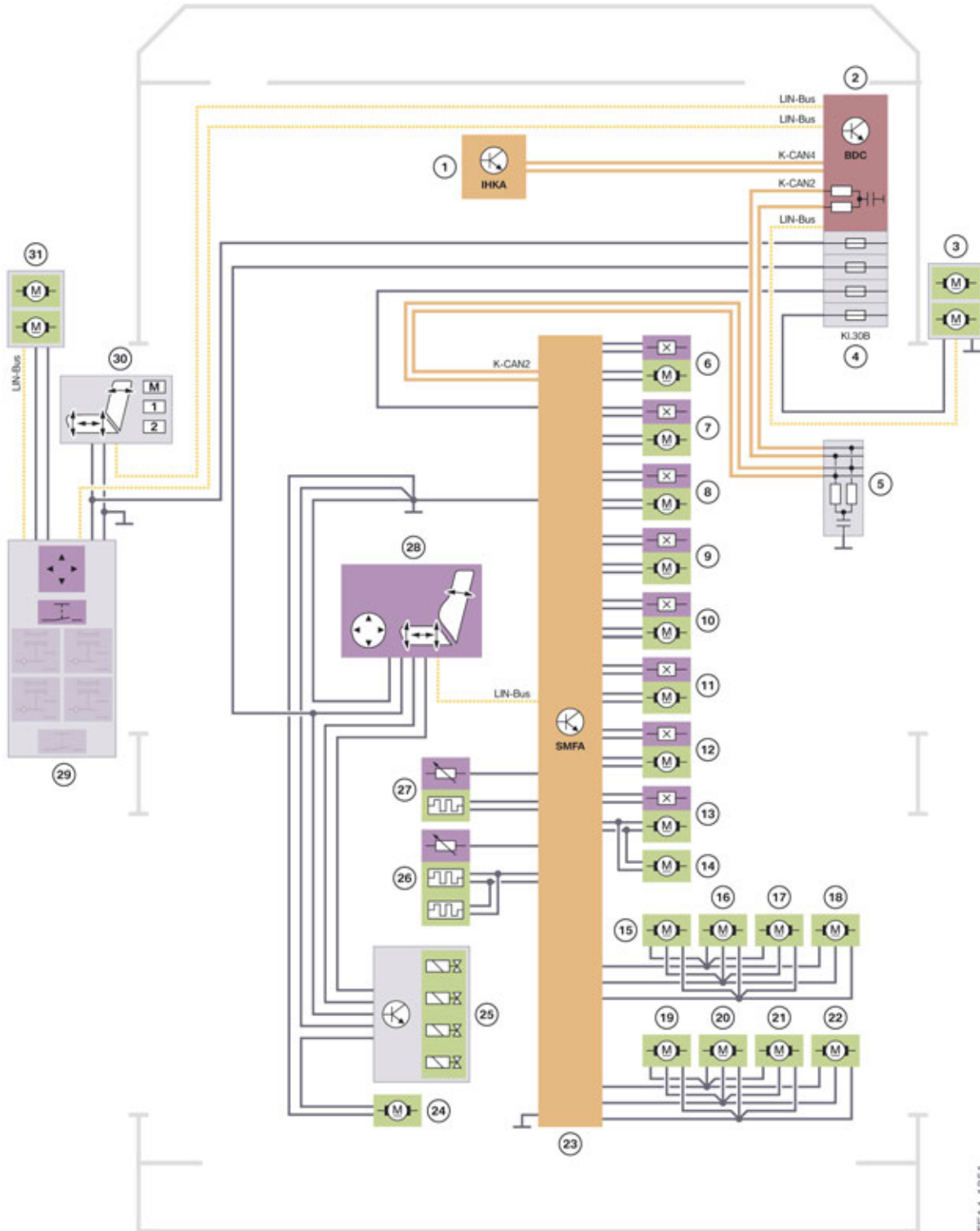

TE14-1251

Multifunction seat, front, driver's side

G12 General Vehicle Electronics

13. Seats

Index	Explanation
1	Integrated automatic heating / air conditioning (IHKA)
2	Body Domain Controller (BDC)
3	Exterior mirror, front passenger side
4	Fuses in the power distribution box, front right
5	CAN terminator
6	Electric motor, forward/back seat adjustment
7	Electric motor, seat angle adjustment
8	Electric motor, seat height adjustment
9	Electric motor, backrest angle adjustment
10	Motor, head restraint height adjustment
11	Motor, seat depth adjustment
12	Motor, backrest upper section adjustment
13	Motor, backrest width adjustment
14	Motor, backrest width adjustment
15	Motor, active seat ventilation, seat surface
16	Motor, active seat ventilation, seat surface
17	Motor, active seat ventilation, seat surface
18	Motor, active seat ventilation, seat surface
19	Motor, active seat ventilation, backrest surface
20	Motor, active seat ventilation, backrest surface
21	Motor, active seat ventilation, backrest surface
22	Motor, active seat ventilation, backrest surface
23	Driver's seat module (SMFA)
24	Lumbar support pump
25	Valve block, lumbar support adjustment
26	Seat heating pad, backrest
27	Seat heating pad, seat surface
28	Switch, seat adjustment
29	Switch block, driver's door
30	Memory switch
31	Exterior mirror, driver's side

G12 General Vehicle Electronics

13. Seats

13.1.4. Multifunction seat, front, passenger's side

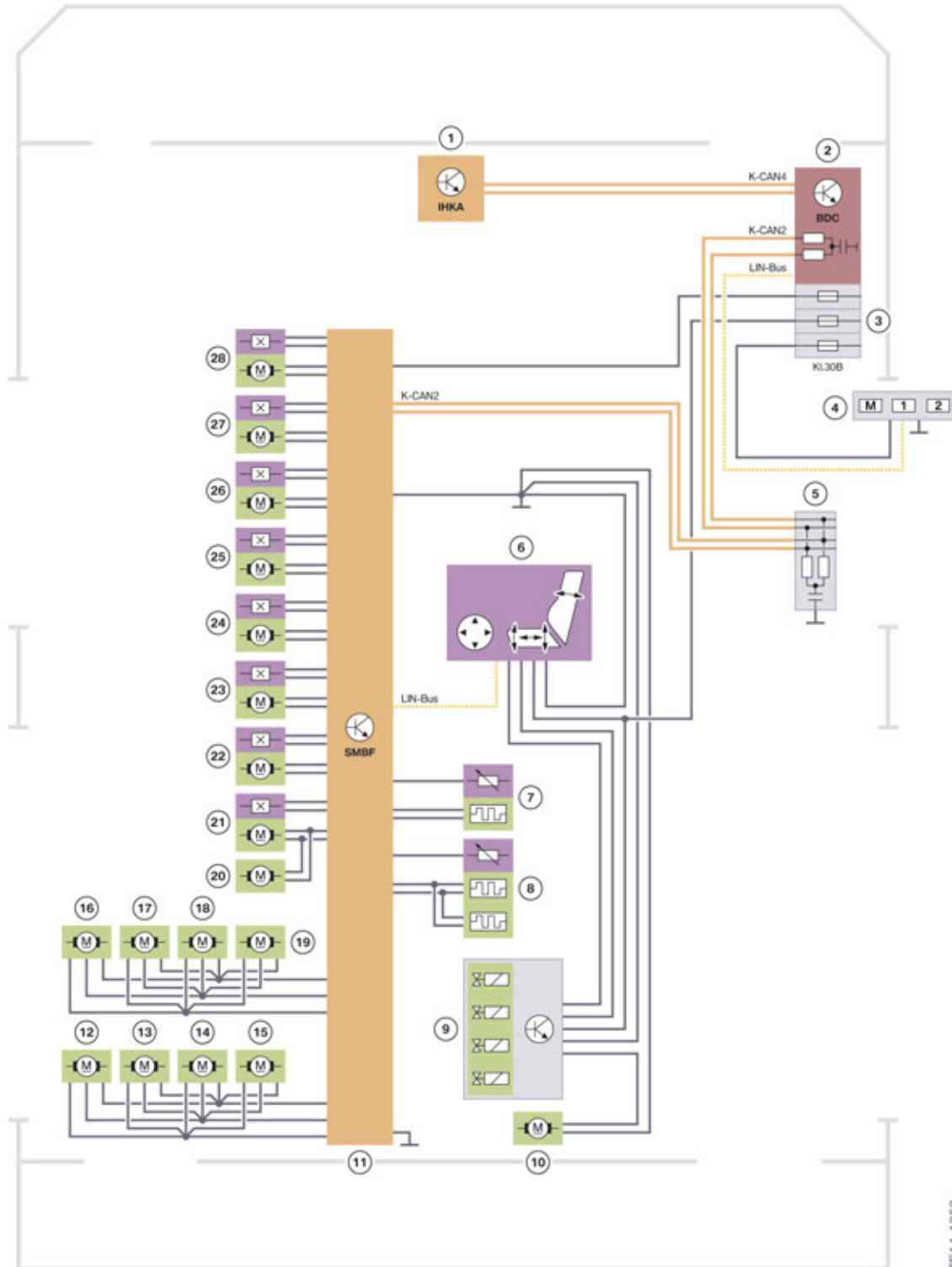

TE14-1252

Multifunction seat, front, passenger's side

G12 General Vehicle Electronics

13. Seats

Index	Explanation
1	Integrated automatic heating / air conditioning (IHKA)
2	Body Domain Controller (BDC)
3	Fuses in the power distribution box, front right
4	Memory switch
5	CAN terminator
6	Switch, seat adjustment
7	Seat heating pad, seat surface
8	Seat heating pad, backrest
9	Valve block, lumbar support adjustment
10	Lumbar support pump
11	Front passenger seat module, (SMBF)
12	Motor, active seat ventilation, backrest surface
13	Motor, active seat ventilation, backrest surface
14	Motor, active seat ventilation, backrest surface
15	Motor, active seat ventilation, backrest surface
16	Motor, active seat ventilation, seat surface
17	Motor, active seat ventilation, seat surface
18	Motor, active seat ventilation, seat surface
19	Motor, active seat ventilation, seat surface
20	Motor, backrest width adjustment
21	Motor, backrest width adjustment
22	Motor, backrest upper section adjustment
23	Motor, seat depth adjustment
24	Motor, head restraint height adjustment
25	Electric motor, backrest angle adjustment
26	Electric motor, seat height adjustment
27	Electric motor, seat angle adjustment
28	Electric motor, forward/back seat adjustment

G12 General Vehicle Electronics

13. Seats

13.2. Rear seats

13.2.1. Seat heating, basic seat, rear passenger compartment

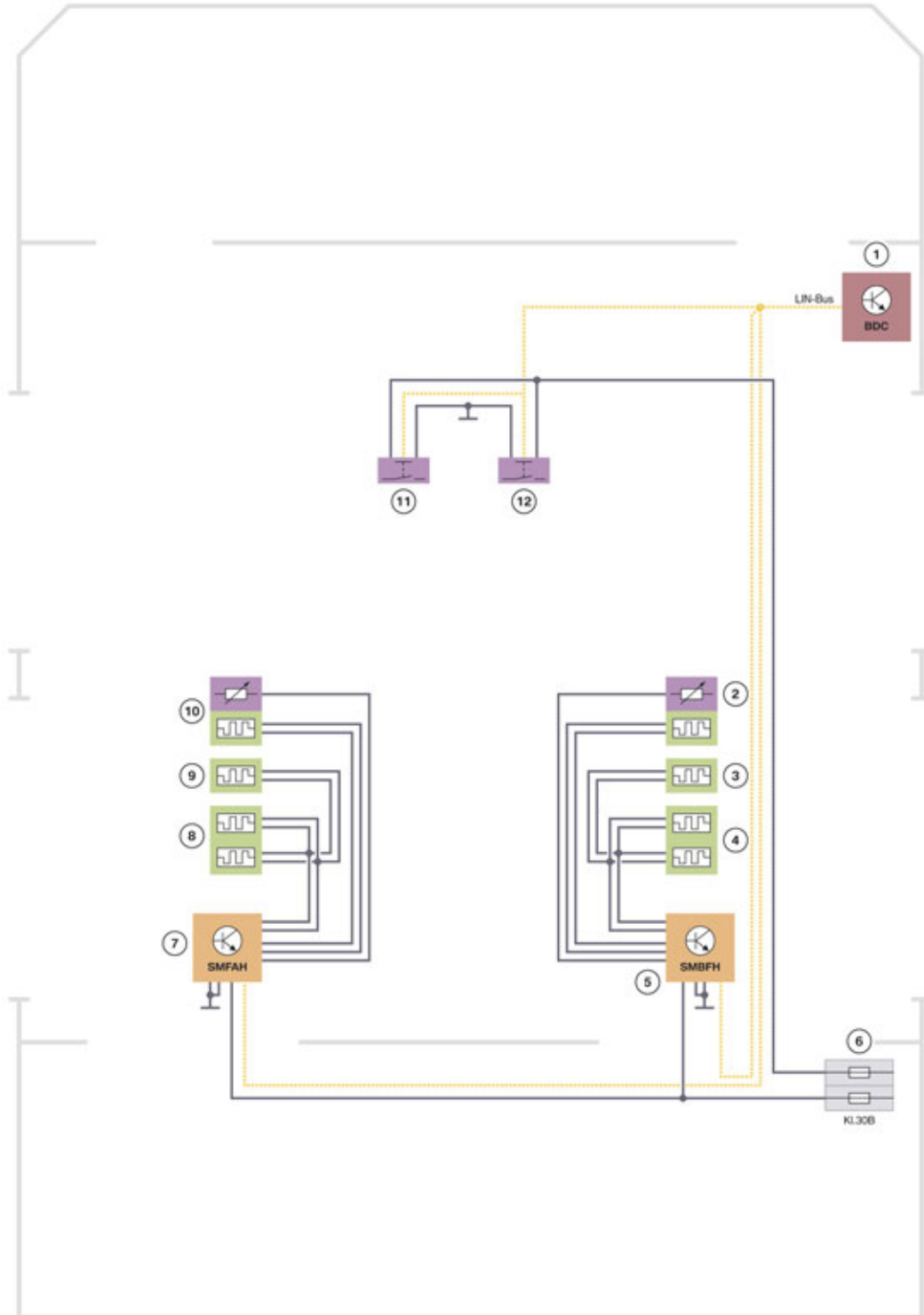

TE14-1254

Seat heating, basic seat, rear passenger compartment

G12 General Vehicle Electronics

13. Seats

Index	Explanation
1	Body Domain Controller (BDC)
2	Seat heating pad, seat surface, passenger's side rear
3	Seat heating pad, backrest, passenger's side rear (equipment-dependent)
4	Seat heating pad, backrest, passenger's side rear
5	Seat-heating electronics, rear passenger side
6	Fuse in the rear power distribution box
7	Seat-heating electronics, rear driver's side
8	Seat heating pad, backrest, driver's side rear
9	Seat heating pad, backrest, driver's side rear (equipment-dependent)
10	Seat heating pad, seat surface, driver's side rear
11	Seat-heating switch, rear left
12	Seat-heating switch, rear right

G12 General Vehicle Electronics

13. Seats

13.2.2. Comfort seat, rear passenger compartment, driver's side

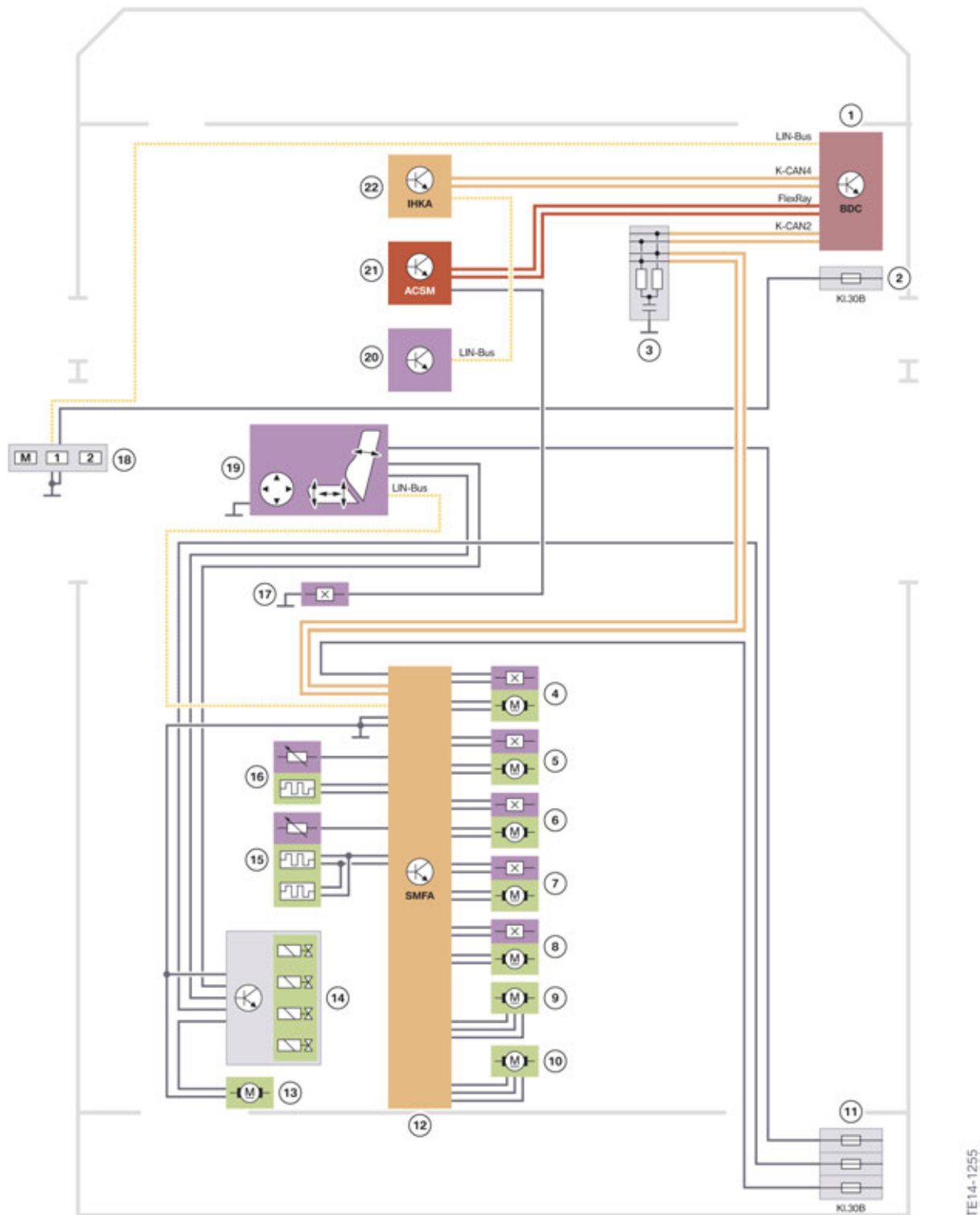

Comfort seat, rear passenger compartment, driver's side

TE14-1255

G12 General Vehicle Electronics

13. Seats

Index	Explanation
1	Body Domain Controller (BDC)
2	Fuse in the power distribution box, front right
3	CAN terminator
4	Electric motor, forward/back seat adjustment
5	Electric motor, seat angle adjustment
6	Electric motor, backrest angle adjustment
7	Motor, backrest upper section adjustment
8	Motor, head restraint height adjustment
9	Motor, backrest width adjustment
10	Motor, backrest width adjustment
11	Fuses in the rear power distribution box
12	Driver's seat module, rear (SMFAH)
13	Lumbar support pump
14	Valve block, lumbar support adjustment
15	Seat heating pad, backrest
16	Seat heating pad, seat surface
17	Seat belt buckle contact, driver's side rear
18	Memory switch
19	Switch, seat adjustment
20	Automatic rear air-conditioning system (FKA)
21	Advanced Crash Safety Module (ACSM)
22	Integrated automatic heating / air conditioning (IHKA)

G12 General Vehicle Electronics

13. Seats

13.2.3. Comfort seat, rear passenger compartment, passenger's side

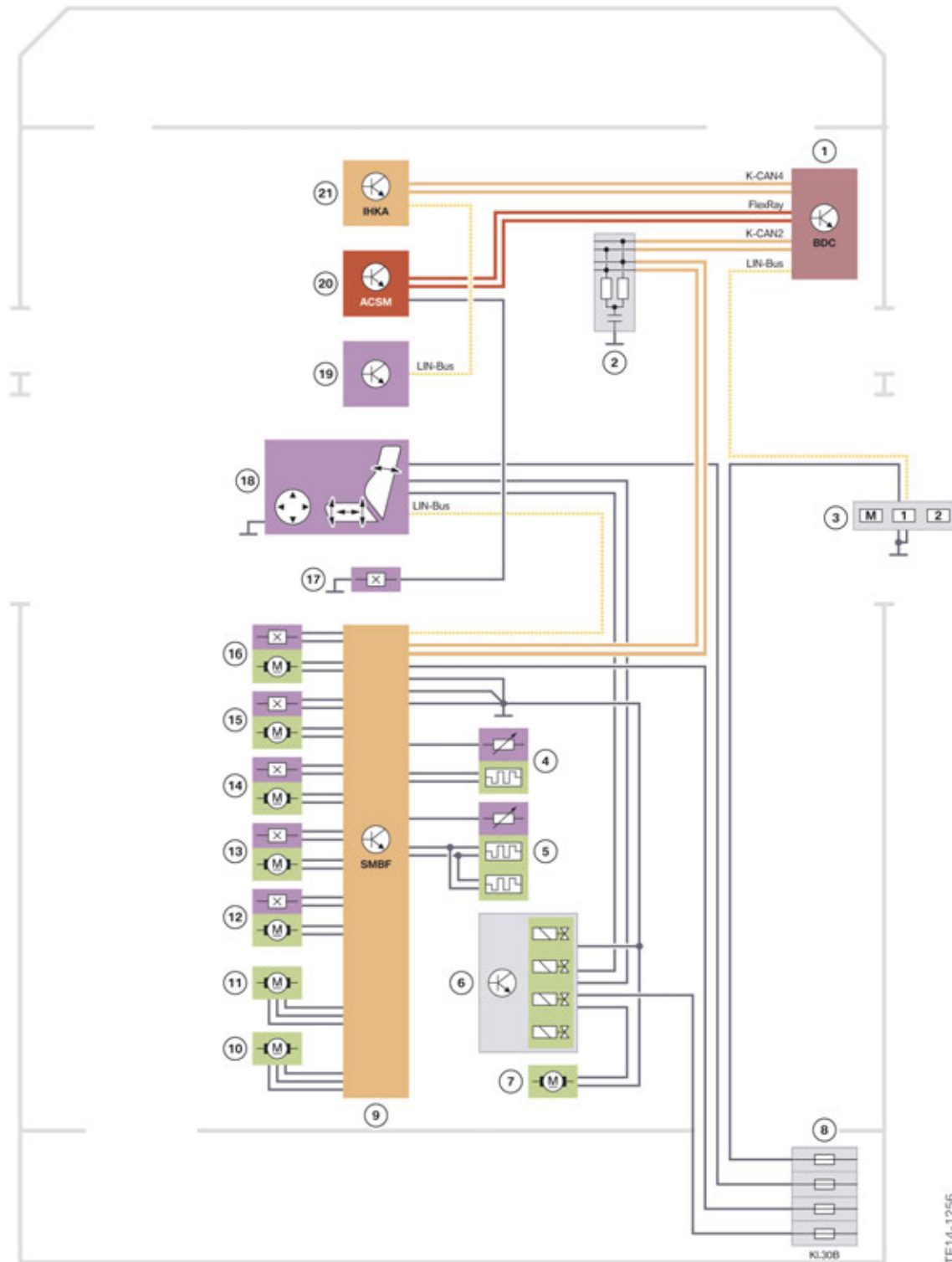

TE14-1256

Comfort seat, rear passenger compartment, passenger's side

G12 General Vehicle Electronics

13. Seats

Index	Explanation
1	Body Domain Controller (BDC)
2	CAN terminator
3	Memory switch
4	Seat heating pad, seat surface
5	Seat heating pad, backrest
6	Valve block, lumbar support adjustment
7	Lumbar support pump
8	Fuses in the rear power distribution box
9	Front passenger seat module, rear (SMBFH)
10	Motor, backrest width adjustment
11	Motor, backrest width adjustment
12	Motor, head restraint height adjustment
13	Motor, backrest upper section adjustment
14	Electric motor, backrest angle adjustment
15	Electric motor, seat angle adjustment
16	Electric motor, forward/back seat adjustment
17	Seat belt buckle contact, passenger's side rear
18	Switch, seat adjustment
19	Automatic rear air-conditioning system (FKA)
20	Advanced Crash Safety Module (ACSM)
21	Integrated automatic heating / air conditioning (IHKA)

13.3. Captain's Chair

The captain's chair has an extended adjustment range in forward direction for the forward/back seat adjustment, a maximized backrest angle, a folding head restraint as well as an integrated footrest in the front passenger seat. The all-round visibility and leg room achieved provides enhanced travel quality for the passenger in the right rear seat (optional equipment — Rear Executive Lounge Seating (SA ZRE)). No lumbar adjustment, massage function or backrest width adjustment are possible for the captain's chair.

The front passenger seat can also be adjusted by means of the seat adjustment controls in the rear passenger compartment.

G12 General Vehicle Electronics

13. Seats

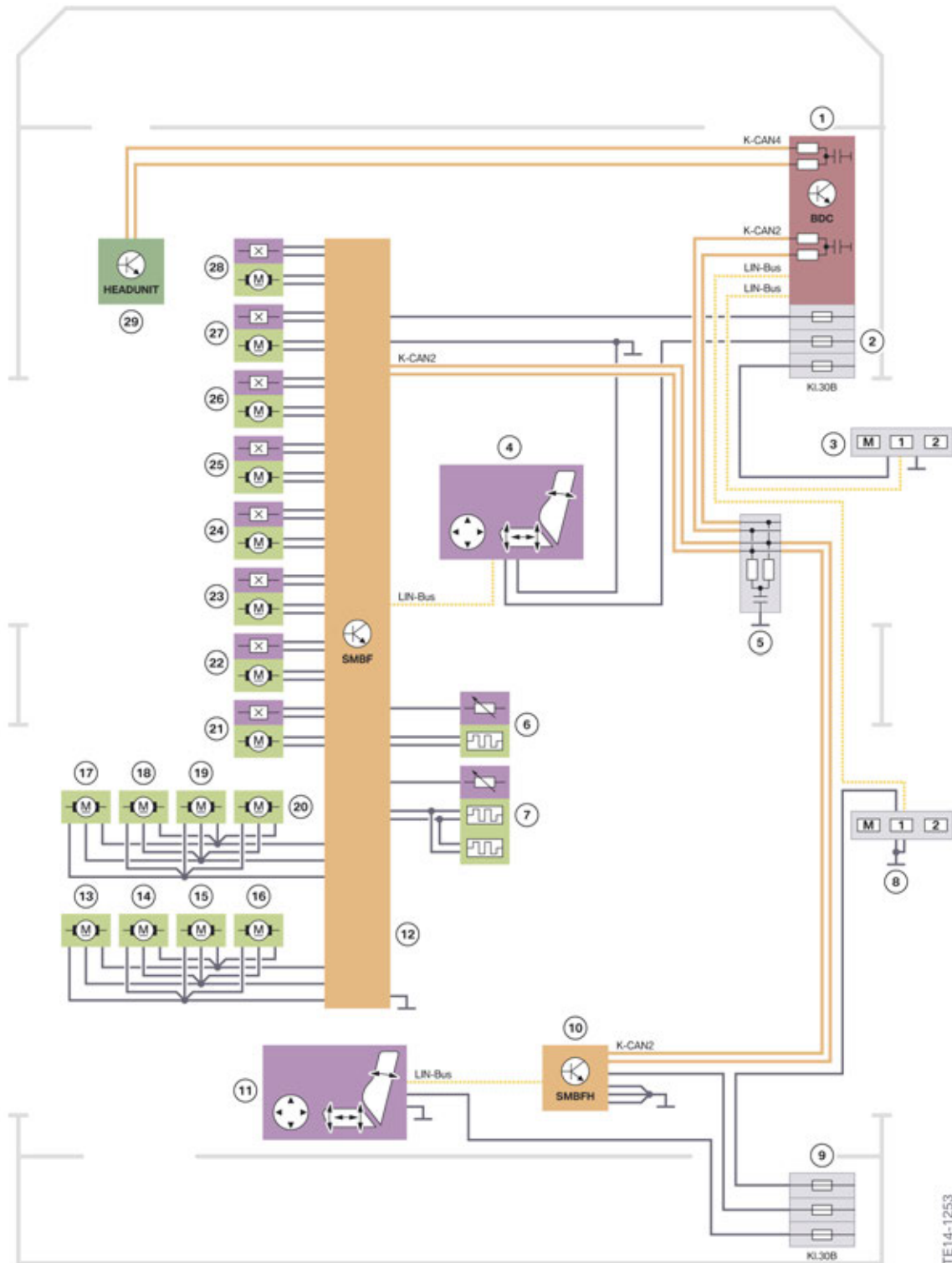

TE14-1253

Captain's Chair

G12 General Vehicle Electronics

13. Seats

Index	Explanation
1	Body Domain Controller (BDC)
2	Fuses in the power distribution box, front right
3	Memory seat, front passenger's side
4	Switch, seat adjustment, passenger's side
5	CAN terminator
6	Seat heating pad, seat surface
7	Seat heating pad, backrest
8	Memory seat, passenger's side rear
9	Fuses in the rear power distribution box
10	Front passenger seat module, rear (SMBFH)
11	Switch, seat adjustment, passenger's side rear
12	Front passenger seat module, (SMBF)
13	Motor, active seat ventilation, backrest surface
14	Motor, active seat ventilation, backrest surface
15	Motor, active seat ventilation, backrest surface
16	Motor, active seat ventilation, backrest surface
17	Motor, active seat ventilation, seat surface
18	Motor, active seat ventilation, seat surface
19	Motor, active seat ventilation, seat surface
20	Motor, active seat ventilation, seat surface
21	Motor for monitor angle adjustment
22	Motor for footrest adjustment
23	Motor for head restraint adjustment
24	Motor, seat depth adjustment
25	Electric motor, backrest angle adjustment
26	Electric motor, seat height adjustment
27	Electric motor, seat angle adjustment
28	Electric motor, forward/back seat adjustment
29	Head unit

G12 General Vehicle Electronics

13. Seats

13.4. Massage

8 different massage functions in the backrest and seat cushion are available to activate or relax muscles. This allows the back muscles to be relaxed and the strain on the spinal discs to be relieved. The 8 programs are divided into 3 categories:

- Mobilization
- Relaxation
- Vitalization

In the case of mobilization, the strain on the spine is relieved by targeted body movements.

In the relaxation program, the muscles are relaxed by massage.

The vitalization program is made up of both mobilization and relaxation. The combination of movement and massage ensures relaxation and recuperation, particularly on long journeys.

G12 General Vehicle Electronics

13. Seats

13.4.1. Seat massage, both front seats

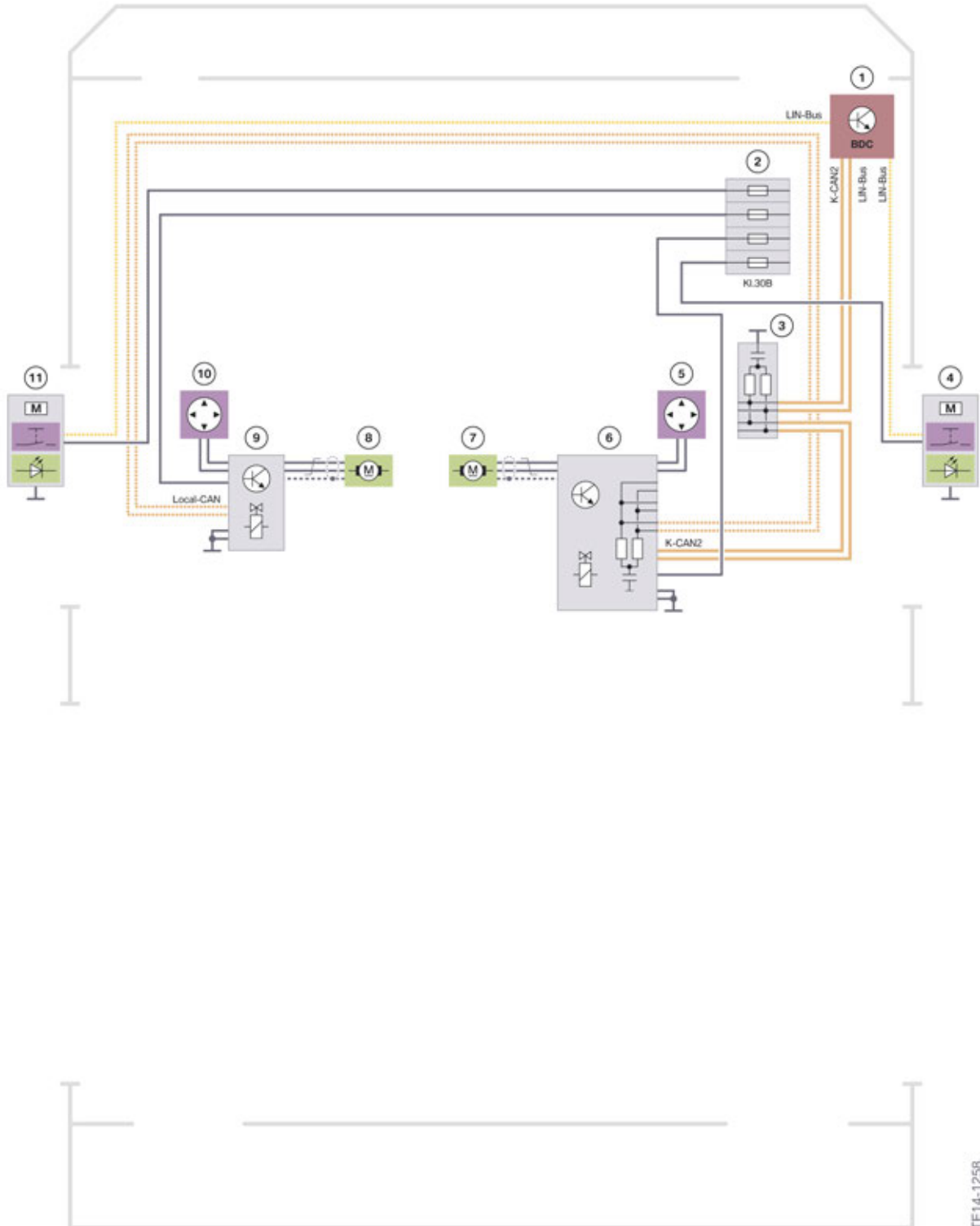

Seat massage, both front seats

TE14-1256

G12 General Vehicle Electronics

13. Seats

Index	Explanation
1	Body Domain Controller (BDC)
2	Fuse in the power distribution box, front right
3	CAN terminator
4	Switch block, front passenger door
5	Switch, lumbar support, front passenger seat
6	Seat pneumatics module front right
7	Lumbar support pump, front passenger seat
8	Lumbar support pump, driver's seat
9	Seat pneumatics module front left
10	Switch, lumbar support, driver's seat
11	Switch block, driver's door

G12 General Vehicle Electronics

13. Seats

13.4.2. Seat massage, rear passenger compartment, and massage, front

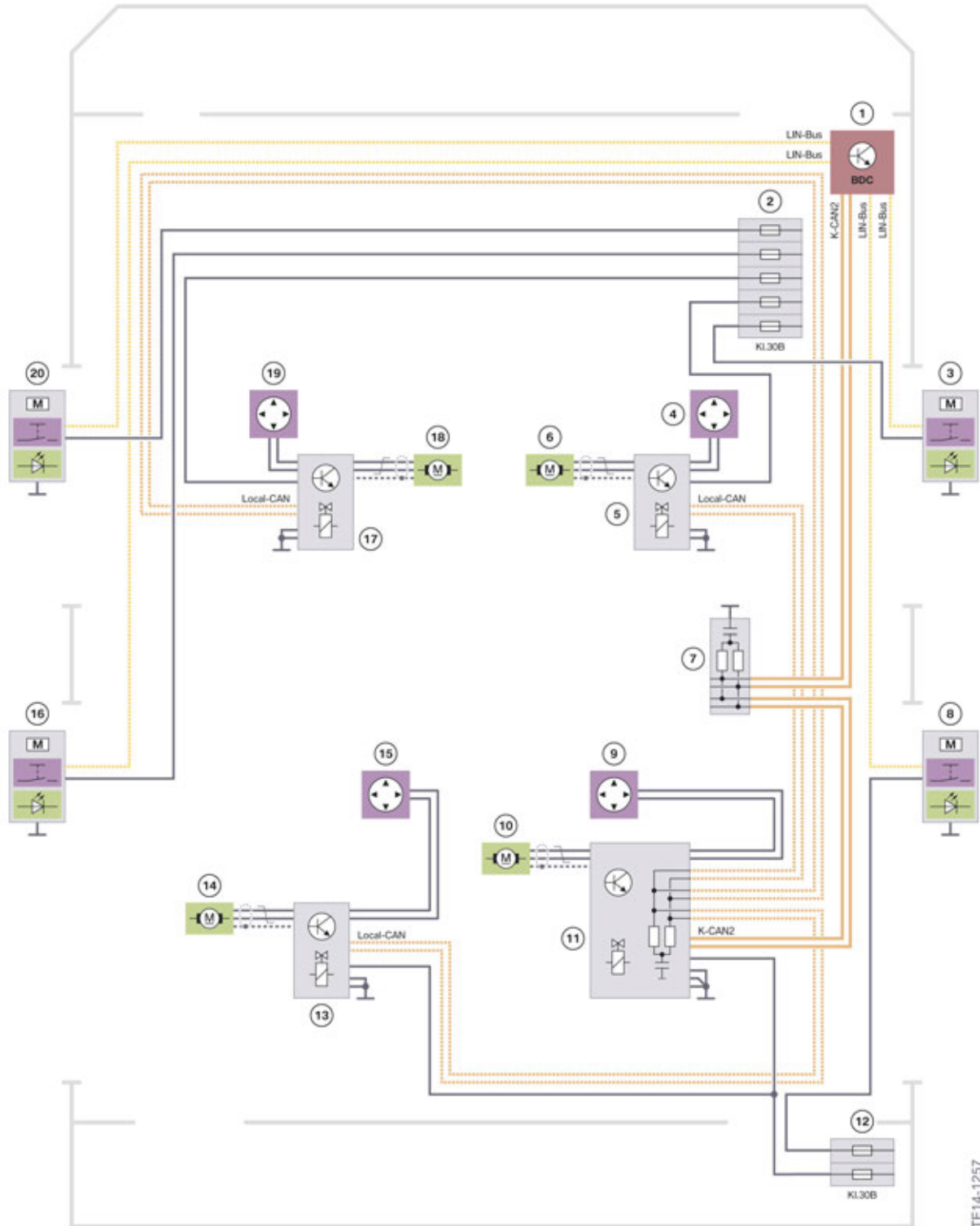

Seat massage, rear passenger compartment, and massage, front

TE14-1257

G12 General Vehicle Electronics

13. Seats

Index	Explanation
1	Body Domain Controller (BDC)
2	Fuse in the power distribution box, front right
3	Switch block, front passenger door
4	Switch, lumbar support, front passenger seat
5	Seat pneumatics module front right
6	Lumbar support pump, front passenger seat
7	CAN terminator
8	Switch block, rear passenger door
9	Switch, lumbar support, rear passenger seat
10	Lumbar support pump, rear passenger seat
11	Seat pneumatics module back right
12	Fuses in the rear power distribution box
13	Seat pneumatics module back left
14	Lumbar support pump, rear driver's-side seat
15	Switch, lumbar support, rear driver's-side seat
16	Switch block, rear driver's-side door
17	Switch, lumbar support, driver's seat
18	Lumbar support pump, driver's seat
19	Switch, lumbar support, driver's seat
20	Switch block, driver's door

13.5. Heated armrests

The armrest heating is also switched by means of the seat-heating switch.

The heating can be controlled individually for each seat by means of the controller.

G12 General Vehicle Electronics

13. Seats

13.5.1. System wiring diagram

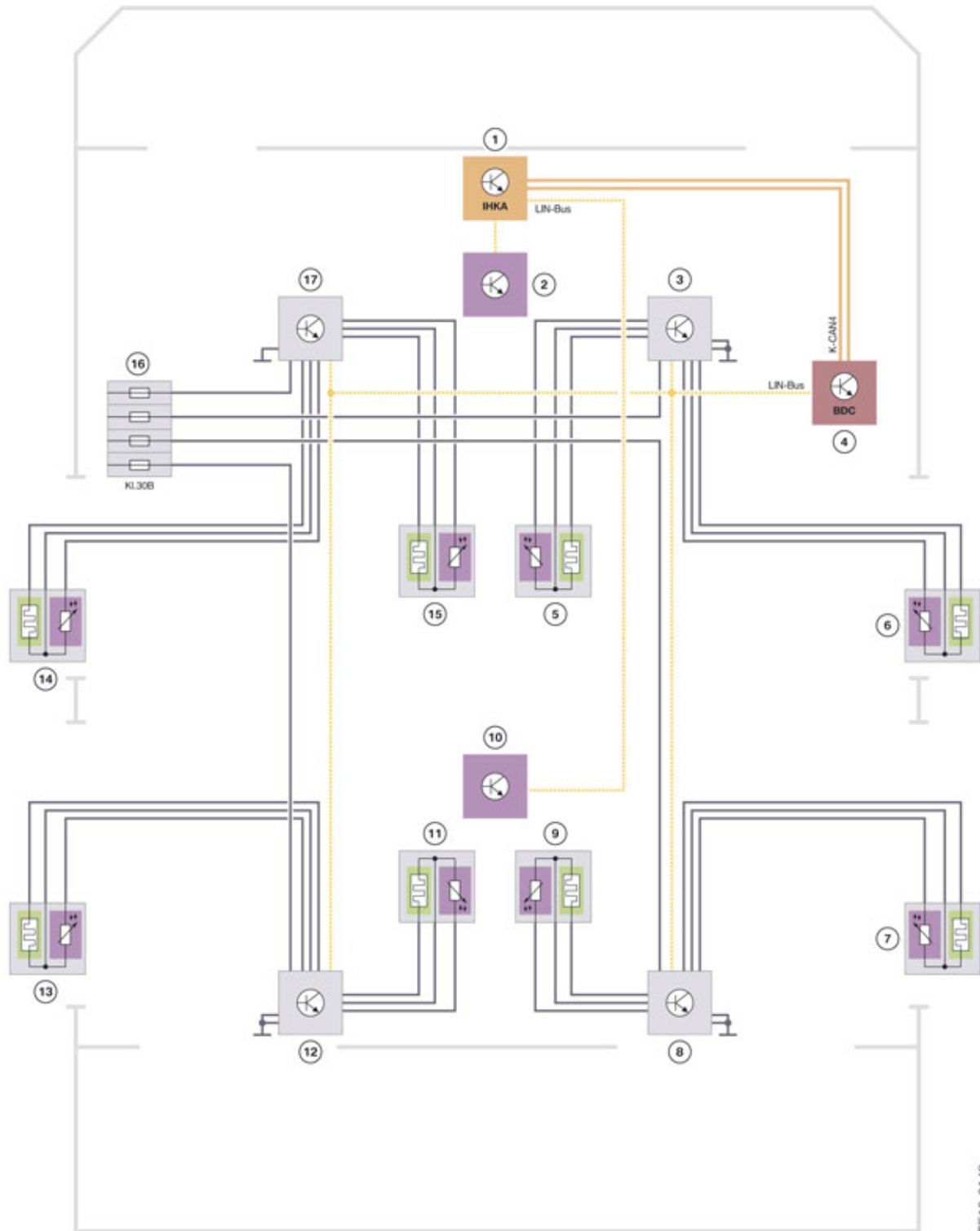

Heated armrests

TE15-0148

G12 General Vehicle Electronics

13. Seats

Index	Explanation
1	Integrated automatic heating / air conditioning
2	Operating unit, air conditioning
3	Control unit for armrest heating, passenger's side
4	Body Domain Controller (BDC)
5	Armrest heating, center console, passenger's side
6	Armrest heating in front passenger door
7	Armrest heating in rear passenger door
8	Control unit for armrest heating, rear passenger's side
9	Armrest heating, center console, rear passenger's side
10	Operating unit for air conditioning, rear passenger compartment, or switch block, rear passenger compartment (equipment-dependent)
11	Armrest heating, center console, rear driver's side
12	Control unit for armrest heating, rear driver's side
13	Armrest heating in rear driver's-side door
14	Armrest heating in driver's door
15	Armrest heating, center console, driver's side
16	Fuses in the power distribution box, front left
17	Control unit for armrest heating, driver's side

13.6. BMW Vitality Program

For the first time at BMW, there is active interaction of the rear seat passenger with the rear seat.

This function allows the customer to relax in a sitting position on long journeys and to regenerate the spinal discs by active movements. The training can be started via Touch Command or with the remote control of the Rear Seat Entertainment. A calibration run is performed for individual adaptation to the occupants. An animation on the rear compartment display shows which movement should be performed. Sensors in the backrest measure the applied pressure, which is displayed on the rear compartment display. The customer is thus given feedback and can respond to this. The training success is displayed at the end of each exercise.

The following optional equipment is required for the BMW Vitality Program:

- Massage, rear passenger compartment (SA 4T6)
- Rear Seat Entertainment (SA 6FR)

G12 General Vehicle Electronics

14. Horn

14.1. System wiring diagram

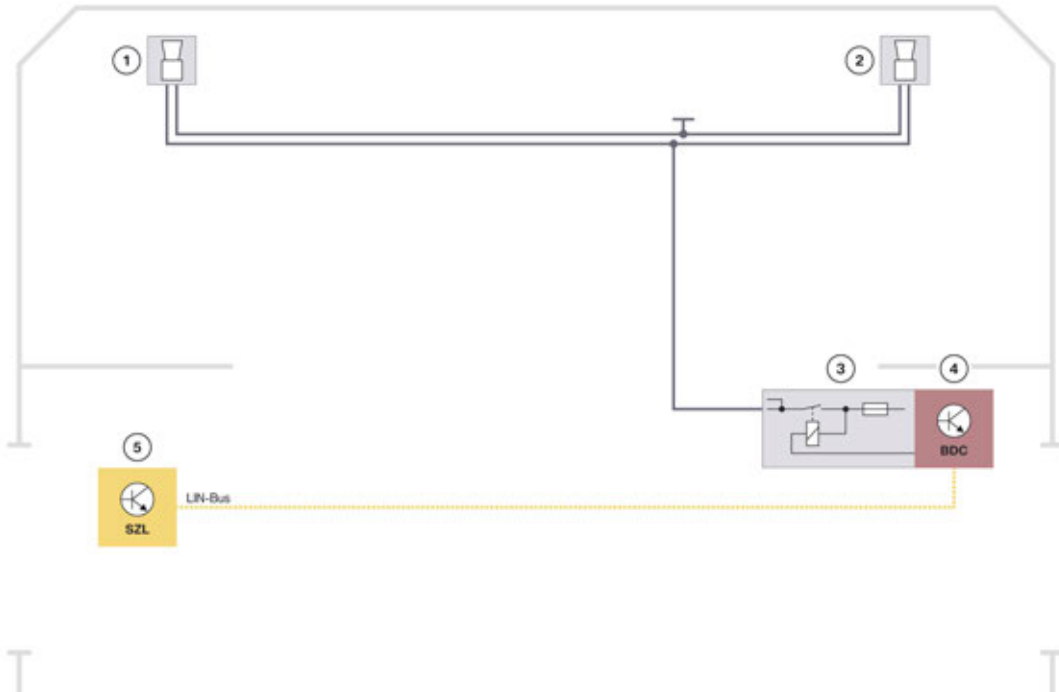

Horns

Index	Explanation
1	Horn, left
2	Horn, right
3	Relay in the Body Domain Controller
4	Body Domain Controller (BDC)

Signal path of horn:

- The horn button is read in by the steering column switch cluster (SZL).
- The SZL sends the information via the local interconnect network bus to the Body Domain Controller.
- The Body Domain Controller evaluates the information and activates the relay for the horn.

TE14-1232



Bayerische Motorenwerke Aktiengesellschaft
Qualifizierung und Training
Röntgenstraße 7
85716 Unterschleißheim, Germany